



DR. BUU NYGREN *PRESIDENT*
RICHELLE MONTOYA *VICE PRESIDENT*

The Navajo Nation | Yideeskáądi Nitsáhákees

February 26, 2024



Teesto Chapter
P.O. Box 7385
Winslow, Arizona 86047

ATTENTION: Elmer Clark, President

REFERENCE: 164 Review 022093 / Contract

Dear Mr. Clark,

Attached please find your copy of the approved Contract (CO16375) with the Navajo Nation Division of Community Development. The Contract has been awarded in the amount of \$1,760,468.00. The term of the contract will commence on February 22, 2024, and expires September 30, 2026.

Reference above contract number on all invoices, documents, and correspondence as it relates to this contract.

Should you have any questions, please contact Dawnell R. Begay at 928.551.8941.

Sincerely,

A handwritten signature in blue ink that reads "Darlene Begay".

Darlene Begay, Senior Accountant
OOC – Contract Administration

xc: **Dawnell R. Begay, Programs & Projects Specialist**, Fiscal Recovery Fund Dept. / Navajo Nation Division of Community Development
Joseph Kaulaity, Principal Accountant, Contract Accounting / Navajo Nation Office of the Controller
Contract Folder: CO16375
File / Chrono

RECEIVED
FEB 27 2004
BY _____



www.fox.com

Document No. 022093

Date Issued: 01/24/2024

SECTION 164 REVIEW FORM

Title of Document: Teesto ARPA Sub-Recipient Agree,emt

Contact Name: BEGAY, DAWNELL RAQUEL

Program/Division: DIV. OF COMMUNITY DEVELOPMENT

Email: dbegay@nndcd.org

Phone Number: (928)551-8941

Check document category: only submit to category reviewers. OMB, OOC and OAG have 5 working days, except BRD has 2 working days, to review and determine whether the document(s) are sufficient or insufficient. If deemed insufficient, a memorandum explaining the insufficiency of the document(s) is required.

Section 164(A)

Division Director: _____

Date: _____

Statement of Policy or Positive Law: Sufficient Insufficient

1. OAG: _____ Date: _____

IGA, Budget Resolutions, Budget Reallocations or amendments: (OMB and Controller sign ONLY if document expends or receives funds)

1. OMB: _____ Date: _____

2. OOC: _____ Date: _____

3. OAG: _____ Date: _____

Section 164(B)

Division Director: 

Date: 1/24/24

Grant/Funding Agreement or amendment:

1. OMB: _____ Date: _____

2. OOC: _____ Date: _____

3. OAG: _____ Date: _____

Subcontract/Contract expending or receiving funds or amendment: NMFRFO State Com 1/26/24

1. BRD:  Date: 01/29/24

2. OMB: CSL Date: 1-30-24

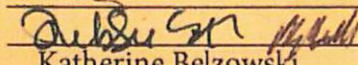
3. OOC:  Date: 2/1/24

4. OAG: Katherine Belzowski Date: 2/15/24

Letter of Assurance/M.O.A./M.O.U./Other agreement not expending funds or amendment:

1. OAG: _____ Date: _____

M.O.A. or Letter of Assurance expending or receiving funds or amendment:

1. OMB: _____ Date: _____

2. OOC: _____ Date: _____

3. OAG: _____ Date: _____

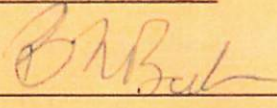
Office of the President/Vice President 

Date: 22 Feb 2024

FEB 1 2024
PROPERTY ACCOUNTS

REC'D
BUSINESS REG.
DEPT.

RECEIVED
JAN 29 2024
THE N.H. OFFICE OF
MANAGEMENT & BUDGET

FEB 2024
1 2 3 4 5 6 7 8 9 10 11 12 13 14 15 16 17 18 19 20 21 22 23 24 25 26 27 28 29 30 31

RECEIVED
FEB 01 2024
OFFICE SERVICES
OFFICE OF THE CONTROLLER

Navajo Nation - Division of Finance

Office of the Controller

164 or Signature Authorization Sheet (SAS) Sign-Off Sheet for OOC

(Attach sign off sheet to SAS document to ensure each section within OOC signs off on SAS)

PLEASE NOTE OOC (ALL SECTIONS IN TOTAL) HAS 7 DAYS TO REVIEW

22093

OOC - Section	Date
1 Accounts Receivable:	_____
2 General Accounting:	_____
3 Contract Accounting:	<u><i>[Signature]</i> 2/1/24</u>
4 Contract Administration:	_____

Comments:

SUFFICIENT. JKawabiy 2/1/2024 rjg



DR. BUU NYGREN *PRESIDENT*
RICHELLE MONTOYA *VICE PRESIDENT*

The Navajo Nation | Yideeskáądi Nitsáhákees

MEMORANDUM

TO: Navajo Nation Section 164 Reviewers

FROM: *Darlene Begay*
 Darlene Begay, Senior Accountant
Contract Administration
Navajo Nation Office of the Controller

THRU: *Valerie Bitsilly*
 Valerie Bitsilly, Accountant
Contract Administration
Navajo Nation Office of the Controller

DATE: February 2, 2024

SUBJECT: Document No. 022093 – Teesto Chapter

Please be advised, the 164 Review Document No. 022093 is complete. Upon review, Navajo Nation Office of the Controller, Contract Administration Section recommends the following deficiency(s) to be addressed and corrected. Should you have any questions, please bring it to my attention at 928.810.8596. Thank you.

- Account Identification: _____
- Cost/Price Analyst Memo: _____
- Term of Contract: _____
- Bids/Advertisements/Quotes or _____
- Sole Source Justification: _____
- Business Regulatory Clearance: _____
- Insurance: _____
- Debarment/Suspension: _____
- W-9: _____
- Other: Attach a total of four (4) copies of the contract upon return for
 (Ex: copies, SOW, signatures,) a contract number.

Contracts and Grants Section / OMB
Document Review Check on Agreement for 2 NNC § 222(A) Action

(Fill in Spaces Highlighted Green that Apply)

Document Review No.: **164 (B) - 022093** Date of Review **1/30/2024**
Navajo Division of Community Development (DCD)
 Sponsor - Title of Program / Division

Agreement / Service Contract - Sec. 164(B) Review

A. K # / Object Code **K2115391.8785 / K2115394.8785 / K2115392.8785** NN Fund B/U

Effective upon Execution by All Parties to September 30, 2026

B. Begin & End Date of Agreement:
3/11/2021 to 12/31/2026

C. Begin & End date of Grant Award, on K # at A. above.

D. **Explanation on purpose of Agreement:**
 SubRecipient between Navajo Nation and Teesto Chapter for purpose of purchasing John Deere 324 G with JRB 48Forks - Forklift, John Deere 724 P Front End Loader, and Weatherization (House Repair)

E. Proposed Amt of Expense:
 K2115391.8785 - \$541,746
 K2115394.8785 - \$1,132,410
 K2115392.8785 - \$86,312

F. Date of FMIS JSI / Budget Balance
 K2115391.8780 - \$541,746
 K2115394.8780 - \$1,132,410
 K2115392.8780 - \$86,312

G. Proposed purchase allowed by SOW? **Yes**

H. Proposed purchase budgeted in grant award? **Yes**

I. **Comment on issues, concerns, etc. on document:**
 Subrecipient between Navajo Nation (DCD) and Teesto Chapter is from Execution by All Parties to September 30, 2026. Per CJN-29-22, Teesto Chapter must ensure cost are incurred by September 30, 2024 and completed by September 30, 2026 unless earlier or later date is determined by the Nation through a resolution. CGS does have concern on No. 1. c. of Agreement as the period of performance states "FRF may be used only to cover costs incurred during the period beginning on March 3, 2021..." but the Nation was not awarded until March 11, 2021.

J. Document is Sufficient or Insufficient: **Sufficient**

K. Review By / Date: **[Signature]** **1/30/24**

Surname By / Date: **CSL** **1.30.24**

Explain in memorandum significant points and issues/concerns noted in Section I above.

FIRM NAME : Teesto Chapter
ADDRESS : P.O. Box 7385
Winslow, Arizona 86047
TELEPHONE NO.: (928) 657 - 8042

**DIVISION OF ECONOMIC DEVELOPMENT
BUSINESS REGULATORY DEPARTMENT**

NAVAJO BUSINESS OPPORTUNITY CLEARANCE

 I certify that the above named person or firm is certified Navajo or Other Indian Owned Firm in accordance with the provisions of current Navajo Tribal Law for enforcement of Navajo Business Opportunity in Tribal Contracting.

 X I certify that the above named person or firm is not certified as a Navajo or Other Indian Firm in accordance with the provisions of current Navajo Tribal Law for enforcement of Navajo Business Opportunity in Tribal Contracting.

 No certified Navajo or Other Indian Firm available for contract performance.

 N/A Attached contract has been let out for bid in accordance with all Tribal Contract Laws - Navajo Business Opportunity Act (5 N.N.C §201 et seq.), Navajo Nation Procurement Code (12 N.N.C. §301 et seq.) and Title Two (2 N.N.C §223). (Invitation to Bid and Bid Results attached). **See Comments Below.**

 N/A This proposed contract is in compliance with applicable Navajo Business Opportunity Act (5 N.N.C §201 et seq.). **See Comments Below.**



Signature

Department Manager I

Title

01/29/24
Date

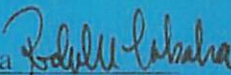
Reviewed by: Rochelle Tabaha  Date: 01/29/2024
Staff Business Regulatory Department

COMMENTS (If Any): Document 022093 is a PSC (Subrecipient Agreement) document between Navajo Nation (DOCD) and the above listed governmental agency. Provisions of the NBOA do not apply in this type of agreement; accordingly, OK to sign off on document as requested. RTabaha



THE
NAVAJO
NATION

TEESTO CHAPTER

P.O. BOX 7385 – Teesto CPU

Winslow, Arizona 86047

Phone: (928) 657-8042 – Fax: (928) 657-8046



"Saddle Butte Mountain"

MEMORANDUM

TO: Arbin Mitchell, Division Director
Jaron Charley, Department Manager II
Ryan Begay, ARPA Projects Manager
Division of Community Development

A handwritten signature in black ink, appearing to read "Elmer Clark".

FROM: Elmer Clark, President
Teesto Chapter

SUBJECT: REQUESTING TO TERMINATE WORK WITH IDSA

DATE: January 19, 2024

Teesto Chapter, an LGA certified chapter, elected to request the assistance and services of Indigenous Design Studio and Architecture (IDSA) on September 7, 2023 to assist with project management related to housing repairs and renovations using ARPA funds.

Teesto Chapter now reconsiders and requests termination of continued work and assistance by IDSA as IDIQ. Teesto Chapter appreciates the assistance IDSA provided. The Chapter Officials and administration feel confident the Chapter can function, manage and deliver the needed repairs to its constituents more efficiently through direct funding and allocation of funds via Sub-Recipient Agreement.

Should you have any questions please do not hesitate to contact me at (928) 606-4136 or Ms. Clara Tsosie, Chapter Manager at (928) 657-8042/8045.

CC:

Arbin Mitchell, Executive Director, DCD
Lisa Jymm, Deputy Director, FRF Office
Lenora Henderson, FRF Office
Clara Tsosie, Chapter Manager
LeRoy Thomas, Vice President
Sophia Francis, Secretary/Treasurer
Cherilyn Yazzie, Council Delegate

*Elmer Clark, President - LeRoy Thomas, Vice President - Sophia Francis, Secretary/Treasurer - Morgan Yazzie,
Grazing Official - Cherilyn Yazzie., Council Delegate (Teesto/Dilkon/Indian Wells/Greasewood/Whitecone)*

FRFO and DCD

Subrecipient Agreement Check-off List

Chapter/Entity: Teesto Chapter

Done <input checked="" type="checkbox"/>		Date	Performed by:	Notes:
<input checked="" type="checkbox"/>	W-9 Form	01/17		
<input checked="" type="checkbox"/>	Suspension and Debarment Form	01/17		
<input checked="" type="checkbox"/>	Initial Risk Assessment evaluation memo		PTA	
<input checked="" type="checkbox"/>	FMIS JSI printed (check LOD 6 object code)	1/23/24	PTA	
N/A	Budget Revision Request (BRR)	N/A		
<input checked="" type="checkbox"/>	Disbursement Schedule revised 1/23/24 <input checked="" type="checkbox"/>	1/23/24	PTA	
<input type="checkbox"/>	Insurance Minimum Letter from Risk Management Department			
<input type="checkbox"/>	164B SRA packet scanned into computer			
<input type="checkbox"/>	E-copy emailed to DOJ, FRFO, DCD or administrative oversight.			
<input type="checkbox"/>	HighQ request to Kayla			
<input type="checkbox"/>	OPVP Request for Services form completed for OPVP Legislative Counsel/President's signature			
<input type="checkbox"/>	Chapter Invoice for first disbursement			



The Navajo Nation **DR. BUU NYGREN** **PRESIDENT**
Yideeskáądi Nitsáhákees **RICHELLE MONTOYA** **VICE PRESIDENT**

DATE: August 28, 2023

TO: Tom Platero, Executive Director
Navajo Nation Fiscal Recovery Fund Office

FROM: 
Arnold Jake, Principal Accountant
Navajo Nation Fiscal Recovery Fund Office

SUBJECT: Initial Risk Assessment for Teesto Chapter

In accordance with 2 CFR §200.206, the Navajo Nation Fiscal Recovery Fund Office (NN FRFO) Finance Section has evaluated the subrecipient's risk of noncompliance based on a set of common factors. These risk assessments may include factors such as prior experience in managing Federal funds, financial stability, management systems and standards, previous audits, personnel, and the ability to effectively implement requirements.

With the concurrence of the Office of the Controller and the Administrative Oversight, the initial Risk Assessment determined that:

Teesto Chapter is evaluated to be a Low-risk subrecipient.

There is a low risk that the subrecipient will fail to meet project or programmatic objectives or incur significant deficiencies in financial, regulatory, reporting, or other compliance requirements.

As needed, the NN FRFO, in consultation with the Office of the Controller and the Administrative Oversight, may perform follow up risk assessments.

If you have any questions, please contact the NN FRFO at (505) 309-5550.



DR. BUU NYGREN **PRESIDENT**

RICHELLE MONTOYA **VICE PRESIDENT**

The Navajo Nation | Yideeskáądi Nitsáhákees

M E M O R A N D U M

TO: Pauline Thomas; Department Manager II
DCD – ARPA – FRF Office

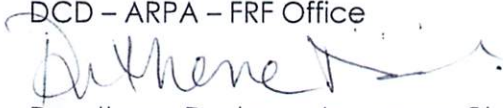
FROM: 
Dorothea Dedman, Insurance Claims Analyst
Risk Management Program

DATE February 19, 2024

SUBJECT INSURANCE MINIMUM – Chapter – Subrecipient Agreement - #022093 –
Teesto Chapter - ARPA Sub-Recipient Agreement

Our Office is in receipt of the above document for review. Review focused primarily on the Subrecipient Agreement. After further review, the Risk Management Program (NNRMP) has the following comments:

1. Teesto Chapter is in good standing with the Risk Management Program. All premiums are paid for FY – 24.
2. Since Teesto Chapter is a member of the Navajo Nation Property & Casualty pool (RMP), the Chapter **has met** the minimum insurance requirements. Please report any Changes or terms of the contract immediately to RMP for review.

If you have any question, please feel free to contact me at extension 6335

cc: Shawnevan Dale, Division Director, DGS



E-MAILED

2/19/24

Request for Taxpayer Identification Number and Certification

Give Form to the requester. Do not send to the IRS.

Go to www.irs.gov/FormW9 for instructions and the latest information.

1 Name (as shown on your income tax return). Name is required on this line; do not leave this line blank.

2 Business name/disregarded entity name, if different from above
TEESTO CHAPTER

3 Check appropriate box for federal tax classification of the person whose name is entered on line 1. Check only one of the following seven boxes.

Individual/sole proprietor or single-member LLC

C Corporation

S Corporation

Partnership

Trust/estate

Limited liability company. Enter the tax classification (C=C corporation, S=S corporation, P=Partnership) ▶ _____

Note: Check the appropriate box in the line above for the tax classification of the single-member owner. Do not check LLC if the LLC is classified as a single-member LLC that is disregarded from the owner unless the owner of the LLC is another LLC that is not disregarded from the owner for U.S. federal tax purposes. Otherwise, a single-member LLC that is disregarded from the owner should check the appropriate box for the tax classification of its owner.

Other (see instructions) ▶ _____

4 Exemptions (codes apply only to certain entities, not individuals; see instructions on page 3):

Exempt payee code (if any) _____

Exemption from FATCA reporting code (if any) _____

(Applies to accounts maintained outside the U.S.)

5 Address (number, street, and apt. or suite no.) See instructions.
PO BOX 7385

6 City, state, and ZIP code
WINSLOW, ARIZONA 86047

7 List account number(s) here (optional)

Requester's name and address (optional)

Print or type. See Specific Instructions on page 3.

Part I Taxpayer Identification Number (TIN)

Enter your TIN in the appropriate box. The TIN provided must match the name given on line 1 to avoid backup withholding. For individuals, this is generally your social security number (SSN). However, for a resident alien, sole proprietor, or disregarded entity, see the instructions for Part I, later. For other entities, it is your employer identification number (EIN). If you do not have a number, see *How to get a TIN*, later.

Note: If the account is in more than one name, see the instructions for line 1. Also see *What Name and Number To Give the Requester* for guidelines on whose number to enter.

Social security number

			-				
--	--	--	---	--	--	--	--

or

Employer identification number

8	6	-	0	6	1	9	2	6	2
---	---	---	---	---	---	---	---	---	---

Part II Certification

- Under penalties of perjury, I certify that:
- The number shown on this form is my correct taxpayer identification number (or I am waiting for a number to be issued to me); and
 - I am not subject to backup withholding because: (a) I am exempt from backup withholding, or (b) I have not been notified by the Internal Revenue Service (IRS) that I am subject to backup withholding as a result of a failure to report all interest or dividends, or (c) the IRS has notified me that I am no longer subject to backup withholding; and
 - I am a U.S. citizen or other U.S. person (defined below); and
 - The FATCA code(s) entered on this form (if any) indicating that I am exempt from FATCA reporting is correct.

Certification instructions. You must cross out item 2 above if you have been notified by the IRS that you are currently subject to backup withholding because you have failed to report all interest and dividends on your tax return. For real estate transactions, item 2 does not apply. For mortgage interest paid, acquisition or abandonment of secured property, cancellation of debt, contributions to an individual retirement arrangement (IRA), and generally, payments other than interest and dividends, you are not required to sign the certification, but you must provide your correct TIN. See the instructions for Part II, later.

Sign Here

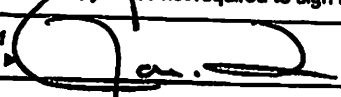
Signature of U.S. person 

Date ▶ January 17, 2024

General Instructions

Section references are to the Internal Revenue Code unless otherwise noted.

Future developments. For the latest information about developments related to Form W-9 and its instructions, such as legislation enacted after they were published, go to www.irs.gov/FormW9.

Purpose of Form

An individual or entity (Form W-9 requester) who is required to file an information return with the IRS must obtain your correct taxpayer identification number (TIN) which may be your social security number (SSN), individual taxpayer identification number (ITIN), adoption taxpayer identification number (ATIN), or employer identification number (EIN), to report on an information return the amount paid to you, or other amount reportable on an information return. Examples of information returns include, but are not limited to, the following.

- Form 1099-INT (interest earned or paid)

- Form 1099-DIV (dividends, including those from stocks or mutual funds)
- Form 1099-MISC (various types of income, prizes, awards, or gross proceeds)
- Form 1099-B (stock or mutual fund sales and certain other transactions by brokers)
- Form 1099-S (proceeds from real estate transactions)
- Form 1099-K (merchant card and third party network transactions)
- Form 1098 (home mortgage interest), 1098-E (student loan interest), 1098-T (tuition)
- Form 1099-C (canceled debt)
- Form 1099-A (acquisition or abandonment of secured property)

Use Form W-9 only if you are a U.S. person (including a resident alien), to provide your correct TIN.

If you do not return Form W-9 to the requester with a TIN, you might be subject to backup withholding. See *What is backup withholding*, later.

NAVAJO NATION CERTIFICATION
Regarding Debarment, Suspension, and
Contracting Eligibility

1. Applicant entity acknowledges that to the best of its knowledge that the Applicant entity, either in its present form or in any identifiable capacity, has not, in accordance with 12 N.N.C. § 361:
 - A. Been convicted of the commission of criminal offenses incident to obtaining or attempting to obtain a public or private contract or subcontract, or in the performance of any such contract or subcontract;
 - B. Been convicted of embezzlement, theft, forgery, bribery, falsification or destruction of records, receiving stolen property, or other offenses indicating a lack of business integrity or honesty, which currently, seriously, and directly affect responsibility as a Navajo Nation contractor;
 - C. Been convicted under antitrust statutes arising out of the submission of bids or proposals;
 - D. Violated contract provisions, including:
 - i. Deliberate failure, without good cause, to perform in accordance with the contract specifications or within the time limit provided in the contract,
 - ii. A recent record of failure to perform or of unsatisfactory performance with the terms of any contract, or
 - iii. Any other cause so serious and compelling as to affect responsibility as a Navajo Nation contractor, including debarment by another governmental entity.
2. Applicant acknowledges that if the Navajo Nation determines that the executed Certification provided herein is untrue or not wholly accurate, it shall be grounds for the Navajo Nation to terminate the contract and pursue other legal remedies, at the Navajo Nation's discretion.
3. Applicant certifies to the best of its knowledge that it is eligible to do business with the

Navajo Nation, in its present form or in any other identifiable capacity, pursuant to 12 N.N.C. § 1501 and 5 N.N.C. § 301. Applicant also acknowledges that per 12 N.N.C. § 1505, it will not be eligible to contract with the Navajo Nation if deemed ineligible by the appropriate department or entity of the Navajo Nation which receives the Applicant's request for consideration for a business opportunity.

Elmer Clark, President



Applicant Name

Teesto Chapter

Applicant Address

PO Box 7385

Applicant Address

Winslow, Arizona 86047

Applicant Address

Clara Tsosie

Name of individual signing on Applicant's behalf (print)

Manager

Title of individual signing on Applicant's behalf

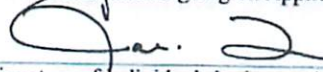

Signature of individual signing on Applicant's behalf

January 16, 2024

Date

Job K2115391 US TREASURY-TEESTO JOHN D 724P
Project

Cost Code	Cost Type	Description	L P M DE C U M	Original	Revised	Actual	Open Commit	Budget	% Revised	% Revised
				Budget Amt	Budget Amt	Amount	Amount	Balance	Spent	Remaining
1710	Program Revenue	6 BN		541,746.00-	541,746.00-			541,746.00-		1.00
1710	Program Revenue	6 T		541,746.00-	541,746.00-			541,746.00-		1.00
1705	CG Revenue	5 T		541,746.00-	541,746.00-			541,746.00-		1.00
1700	External C/G Revenue Source	4 T		541,746.00-	541,746.00-			541,746.00-		1.00
1000	Revenues	3 T		541,746.00-	541,746.00-			541,746.00-		1.00
8780	Entities	6 BN		541,746.00	541,746.00			541,746.00		1.00
8780	Entities	6 T		541,746.00	541,746.00			541,746.00		1.00
8700	Grants	5 T		541,746.00	541,746.00			541,746.00		1.00
8000	Assistance	4 T		541,746.00	541,746.00			541,746.00		1.00

Job K2115391 US TREASURY-TEESTO JOHN D 724P

Project

Cost Code	Cost Type	Description	L P M D E C U M	Original Budget Amt	Revised Budget Amt	Actual Amount	Open Commit Amount	Budget Balance	% Revised Spent	% Revised Remaining
2000	Expenses		3 T	541,746.00	541,746.00			541,746.00		1.00

Job K2115392 US TREASURY-TEESTO JOHN D 324G

Project

Cost Code	Cost Type	Description	L P M	Original Budget Amt	Revised Budget Amt	Actual Amount	Open Commit Amount	Budget Balance	% Revised Spent	% Revised Remaining
1710		Program Revenue	6 B N	86,312.00-	86,312.00-			86,312.00-		1.00
1710		Program Revenue	6 T	86,312.00-	86,312.00-			86,312.00-		1.00
1705		CG Revenue	5 T	86,312.00-	86,312.00-			86,312.00-		1.00
1700		External C/G Revenue Sourc	4 T	86,312.00-	86,312.00-			86,312.00-		1.00
1000		Revenues	3 T	86,312.00-	86,312.00-			86,312.00-		1.00
8780		Entities	6 B N	86,312.00	86,312.00			86,312.00		1.00
8780		Entities	6 T	86,312.00	86,312.00			86,312.00		1.00
8700		Grants	5 T	86,312.00	86,312.00			86,312.00		1.00
8000		Assistance	4 T	86,312.00	86,312.00			86,312.00		1.00
2000		Expenses	3 T	86,312.00	86,312.00			86,312.00		1.00

Job K2115394 USTREASURY-TEESTO HSING REPAIR

Thru Date 1/31/2024

Project

Cost Code	Cost Type	Description	L P M DE CUM	Original	Revised	Actual	Open Commit	Budget	% Revised	% Revised
				Budget Amt	Budget Amt	Amount	Amount	Balance	Spent	Remaining
1710	Program Revenue	6 BN		1,132,410.00-	1,132,410.00-			1,132,410.00-		1.00
1710	Program Revenue	6 T		1,132,410.00-	1,132,410.00-			1,132,410.00-		1.00
1705	CG Revenue	5 T		1,132,410.00-	1,132,410.00-			1,132,410.00-		1.00
1700	External C/G Revenue Sourc	4 T		1,132,410.00-	1,132,410.00-			1,132,410.00-		1.00
1000	Revenues	3 T		1,132,410.00-	1,132,410.00-			1,132,410.00-		1.00
8780	Entities	6 BN		1,132,410.00	1,132,410.00			1,132,410.00		1.00
8780	Entities	6 T		1,132,410.00	1,132,410.00			1,132,410.00		1.00
8700	Grants	5 T		1,132,410.00	1,132,410.00			1,132,410.00		1.00
8000	Assistance	4 T		1,132,410.00	1,132,410.00			1,132,410.00		1.00
2000	Expenses	3 T		1,132,410.00	1,132,410.00			1,132,410.00		1.00

**SUBRECIPIENT AGREEMENT
BETWEEN
THE NAVAJO NATION AND Teesto Chapter
FOR**

**SUBAWARD OF AMERICAN RESCUE PLAN ACT FISCAL RECOVERY FUNDS
FOR PURPOSES OF**

**John Deere 324G (6.1), John Deere 724P Front End Loader (6.1) & House Repair- Weatherization
(2.18)**

Name of Subrecipient Teesto Chapter		Phone Number (928) 657- 8042	
Name and Title of Person Authorized to accept funding for the Subrecipient ("Designated Official") Elmer Clark, Chapter President		Designated Official's Email Address clark_elmer@yahoo.com	
Subrecipient's Mailing Address PO Box 7385 Winslow, AZ 86047			
Subrecipient's Employer Identification Number 86-0619262			
Subrecipient's DUNS Number & Unique Entity Identifier ("UEI") Number N/A			
Federal Awarding Agency; Assistance Listing Number & Title; Federal Award Date U.S. Department of Treasury; 21.027; May 27, 2021			
Expenditure Plan Title: John Deere 324G with Forklifts (6.1) John Deere 724P (6.1) House Repair - Weatherization (2.18)			
Period of Performance See paragraph 5(b)		Amount of Subaward and Business Units \$ 1,760,468.00 K2115391.8785 \$ 641,746.00 K2115394.8785 \$ 1,132,410.00 K2115392.8785 \$ 86,312.00	

This Subrecipient Agreement includes and incorporates:

1. Terms and Conditions;
2. Appendix A – Scope of Work
3. Appendix B – Budget
4. Appendix C – Disbursement Schedule
5. Appendix D – Expenditure Plan
6. Appendix E – Council Resolution Approving Expenditure Plan
7. Appendix F – Financial Assistance Agreement between Department of Treasury and The Navajo Nation
8. Appendix G - U.S. Department of Treasury Compliance and Reporting Guidance for SLFRF

A complete Subrecipient Agreement, including all Appendices, must be submitted prior to disbursement of the awarded Navajo Nation Fiscal Recovery Funds ("Subaward Funds").

TERMS AND CONDITIONS

This Subrecipient Agreement (“Agreement”) is made and entered into by and between the Navajo Nation, hereinafter called the “NATION” and the “Teesto Chapter” hereinafter called the “SUBRECIPIENT.” Collectively, the NATION and the SUBRECIPIENT are the “PARTIES.”

WHEREAS, the U.S. Department of the Treasury (“Treasury”) has allocated to the NATION funding from the Coronavirus State and Local Fiscal Recovery Fund under Section 603(b) of the Social Security Act, as amended by Section 9901 of the American Rescue Plan Act (“ARPA”), for the limited purposes identified in the Interagency Agreement between Treasury and the NATION, identified as Appendix F, the Coronavirus State and Local Fiscal Recovery Funds Final Rule (“Final Rule”) and other Treasury guidance in the form of Frequently Asked Questions, and the Compliance and Reporting Guidance for SLFRF (“Compliance and Reporting Guidance”), identified as Appendix G, all of which are incorporated herein by this reference.

WHEREAS, the ARPA authorizes the NATION to expend the Fiscal Recovery Funds (“FRF”) awarded to the NATION for the following eligible purposes as outlined in the Final Rule as follows:

(1) To respond to the COVID-19 public health emergency or its negative economic impacts, including assistance to households, small businesses, and nonprofits, or aid to impacted industries such as tourism, travel, and hospitality;

(2) To respond to workers performing essential work during the COVID-19 public health emergency by providing premium pay to eligible workers;

(3) For the provision of government services to the extent of the reduction in revenue due to the COVID-19 public health emergency relative to revenues collected in the most recent full fiscal year prior to the emergency; and

(4) To make necessary investments in water, sewer, or broadband infrastructure.

WHEREAS, the PARTIES desire to enter into this Agreement so that the NATION may provide a subaward of FRF for appropriate and qualifying expenditures of FRF to execute projects or programs outlined in the Expenditure Plan approved by the NATION through Council Resolution CJY-56-23 as specified in **Appendix D**.

NOW, THEREFORE, in consideration of the foregoing recitals which are incorporated herein by reference, and the terms and conditions set forth below, the PARTIES agree as follows:

1. Definitions.

a. “Disburse / Disbursement” is defined as when the Office of the Controller (“OOC”) issues a check or initiates the transfer of Funds into the SUBRECIPIENT’S account.

b. “Expenditure Plan” is the SUBRECIPIENT’S Fiscal Recovery Funds Request Form and Expenditure Plan, with budget, and supporting documents, attached as **Appendix D**.

c. To “Incur” costs means that the SUBRECIPIENT has obligated the Subaward Funds. FRF may be used only to cover costs incurred during the period beginning on March 3, 2021 and ending September 30, 2024.

- d. To "Obligate" funds means orders placed for property and services, contracts and subawards made, and similar transactions during a given period that require payment by the **SUBRECIPIENT** during the same or a future period.
- e. "Expend" is defined as when an expense is actually paid by the **SUBRECIPIENT**.

2. Applicability of Subrecipient Agreement and Provisions.

This Agreement, including all its Appendices, is intended to be the full and complete expression of, and shall constitute the entire agreement between the Parties. All prior and contemporaneous understandings, agreements, promises, representations, terms and conditions, whether oral or written, are superseded and replaced by this Agreement.

3. Authorized Representative and Administrative Oversight.

- a. The **SUBRECIPIENT** shall work with the Division of Community Development ("Administrative Oversight"), and its Authorized Representative with respect to this Agreement.
- b. Each Party shall appoint an Authorized Representative who has the authority and requisite experience to manage all Agreement related matters. Notice of the appointed Authorized Representative shall be provided to each Party within five (5) calendar days of the execution of this Agreement. If either party changes its Authorized Representative or their scope of authority, they shall immediately notify the other Party pursuant to Article 12.
- c. The Administrative Oversight shall serve as the administrative oversight of this Agreement including the **SUBRECIPIENT's** compliance with applicable federal and Navajo Nation laws, regulations, and policies; and financial reporting.

4. Agreement Number.

Contract number C-_____, as assigned by the Office of the Controller, shall cover this Agreement. Reference to this number shall be made on request for release of Subaward Funds submitted by the **SUBRECIPIENT** to the **NATION** for payment.

5. Effective Date and Period of Performance.

- a. This Agreement is effective upon execution by all the **PARTIES**.
- b. The period of performance shall begin on the Effective Date of this Agreement. The **SUBRECIPIENT** shall be required to incur costs, meaning to obligate funds by September 30, 2024, and expend funds by September 30, 2026 unless an earlier or later date is determined by the **NATION** through a resolution of the Navajo Nation Council or a Standing Committee of Council, and with written notice provided to the **SUBRECIPIENT**. The period of performance shall end upon the acceptance and approval by the Authorized Representative, the FRF Office, OMB, and OOC of the **SUBRECIPIENT's** final financial close out report and performance report.

6. Amount and Payment of Subaward.

- a. The **NATION** agrees to allocate and disburse the Subaward Funds to the **SUBRECIPIENT**

\$1,760,468.00 (“Subaward Funds”), per **Appendix B – Budget**.

- b. Payments of the Subaward Funds shall be made in installments according to the Disbursement Schedule in **Appendix C** to this Agreement, which shall be subject to approval by the FRF Office in consultation with OOC and the Administrative Oversight. The **NATION** may withhold or delay disbursements if the **NATION** determines that the **SUBRECIPIENT** has failed to comply with its obligations under this Agreement. This determination shall be made by the FRF Office in consultation with OOC and the Administrative Oversight. The **SUBRECIPIENT** must provide documentation that it has obligated or expended 75% of its prior disbursement installment before OOC will release the next disbursement installment. If the **SUBRECIPIENT** expends 75% of its disbursement installment prior to the end of a twelve-month period, the **SUBRECIPIENT** may request to the FRF Office, the Administrative Oversight, and OOC that OOC release the next disbursement installment prior to the end of that twelve-month period.
- c. No payment of Subaward Funds shall be made unless and until approved by the FRF Office, the Administrative Oversight, and OOC. The **NATION**'s approval of payments of Subaward Funds shall be based on the **SUBRECIPIENT**'s actual costs and achievement of project milestones in accordance with the Disbursement Schedule. The **NATION** may request that the **SUBRECIPIENT** provide supporting documentation of actual costs, including but not limited to work orders, contracts, purchase orders, invoices, and receiving records.
- d. The **SUBRECIPIENT** shall work with the Accounts Payable Section of OOC to set up ACH (Automated Clearing House) electronic fund transfers, and shall provide OOC with an updated W-9 form on an annual basis.

7. Use and Return of Funds.

- a. FRF comprising the Subaward Funds, may only be used pursuant to Section 9901 of the ARPA and all the rules, regulations, and guidance implementing Section 9901 of the ARPA that are applicable to Tribal governments and their subrecipients. The use of FRF must also comply with all applicable Navajo Nation laws.
- b. The **SUBRECIPIENT** affirms and agrees that it shall only incur costs under the Subaward and expend Subaward Funds for the purposes outlined in **Appendix A – Scope of Work**.
- c. If any portion of Subaward Funds remain unexpended on September 30, 2026, unless an earlier or later date is determined by the **NATION** through a resolution of the Navajo Nation Council or a Standing Committee of Council, **SUBRECIPIENT** shall immediately return such portion of the Subaward Funds to the **NATION**. Upon the termination of this Agreement, the **SUBRECIPIENT** may be required to immediately return the unexpended portion of the Subaward Funds to the **NATION**.
- d. Where the **NATION** determines the **SUBRECIPIENT** expended Subaward Funds in violation of this Agreement or any applicable laws and regulations, the **SUBRECIPIENT** shall immediately return such portion of the Subaward Funds the **NATION** determined were improperly expended.

e. If the **SUBRECIPIENT** fails to return such Subaward Funds to the **NATION** when due, the **SUBRECIPIENT** will incur a delinquent accounts receivable debt, due and owing to the **NATION**. Further, the **NATION** may offset any future payments due to the **SUBRECIPIENT** by the amount owed, and may pursue all other available legal action against the **SUBRECIPIENT**.

8. **Pre-Agreement Costs.**

Costs incurred before the finalization of this Agreement that are within the scope of work of the Agreement and that the **NATION** deems reasonable, allowable, and allocable to performance of the Agreement may be paid under this Agreement. This determination shall be made by the FRF Office in consultation with the Administrative Oversight and OOC. All pre-Agreement costs shall be subject to the terms of this Agreement as if such Agreement were in effect when the costs were incurred.

9. **Contingency Reserve.**

If the scope of work of this Agreement involves construction, the **SUBRECIPIENT** may, but shall not be required to, include a portion of the Subaward as a contingency reserve to cover cost overruns due to the inflationary costs of building materials and labor or other construction contingencies. In the event of a cost overrun due to construction contingencies, the **SUBRECIPIENT** shall first exhaust its own internal funding sources, and then may notify the Authorized Representative and Administrative Oversight of its need to access funds from the Navajo Nation Construction Contingencies Expenditure Plan approved in section 13 of Council Resolution CJN-29-22 which are subject to an administrative approval process. If the contingency cannot be funded through the Construction Contingencies Expenditure Plan, the Administrative Oversight may choose to seek approval of a supplemental appropriation of funds through a resolution approved by the Navajo Nation Council.

10. **Administrative Costs.**

The **NATION** shall allow the **SUBRECIPIENT** to budget and expend two percent (2%) of the total Subaward for administrative costs. The **SUBRECIPIENT** may use funds for administering the **SUBRECIPIENT**'s FRF projects and programs under the approved Expenditure Plan, including costs of consultants to support effective management and oversight, including consultation for ensuring compliance with legal, regulatory, and other requirements. Further, costs must be reasonable and allocable as outlined in 2 CFR 200.404 and 2 CFR 200.405. The **SUBRECIPIENT** is permitted to charge both direct and indirect costs as administrative costs. If the total Subaward is not fully expended within the terms of the Agreement, the **SUBRECIPIENT** shall be required to immediately return to the **NATION** the remaining balance of the Subaward Funds, and an additional amount to include the 2% for administrative costs of the balance of the Subaward Funds, even if the **SUBRECIPIENT** fully expended the administration funds.

11. **Availability of Funds.**

The liability of the **NATION** under this Agreement is contingent upon the availability of funds pursuant to 2 N.N.C. §§ 223(A) and (B).

12. **Contact Information; Notice.**

Copies of all correspondence, reports, and notices under this Agreement shall be furnished to the Authorized Representative, with a copy to the FRF Office, OOC and Office of Management and Budget ("OMB") Contracts and Grants Section.

13. Reporting Requirements.

- a. The **SUBRECIPIENT** shall adhere to the following reporting requirements and provide the documentation requested on a monthly basis, unless specified otherwise, to the Administrative Oversight, with a copy to the FRF Office, OOC, and OMB, within ten (10) calendar days following the end of the month.
- b. The **NATION** requires the monthly reporting requirements listed below from the **SUBRECIPIENT**:
 - i. A detailed report that compares budgeted expenditures to actual expenditures for costs incurred;
 - ii. Completion of the OMB Program Performance Criteria Form;
 - iii. A narrative report providing monthly project assessment, including a summary of project activities, accomplishments with dates, impediments encountered, and impediments forecasted with planned responses;
 - iv. A listing of all property purchased with the Subaward Funds costing \$5,000 or more with an expected useful life of more than one year, such as buildings, vehicles, machinery, and equipment; and
 - v. Other data, records, information, and maps related to the progress of the project, that document changes made to the project since the previous monthly report.
- c. The FRF Office, in consultation with OOC and the Administrative Oversight performed a risk assessment on the **SUBRECIPIENT**. The **SUBRECIPIENT** was determined to be low risk. The risk assessment included consideration of such factors as: the **NATION's** evaluation of the **SUPRECIPIENT's** past performance in the context of other subawards, grants, contracts, or other transactions and business opportunities; the **SUBRECIPIENT's** prior experience with similar subawards; the results of previous audits and whether the **SUBRECIPIENT** receives a Single Audit; whether the **SUBRECIPIENT** has new personnel or new or substantially changed systems; and the extent and results of federal funding agency monitoring. The **NATION** may repeat its risk assessment evaluation of the **SUBRECIPIENT** at any time during the term of this Agreement. Additional considerations may include the **SUBRECIPIENT's** compliance or noncompliance with reporting requirements and other terms and conditions of this Agreement.
- d. Depending on the **NATION's** assessment of risk posed by the **SUBRECIPIENT**, the **NATION** may impose additional monitoring tools to ensure the **SUBRECIPIENT's** accountability and compliance with Subaward requirements and achievement of performance goals. This could include the **NATION**: providing the **SUBRECIPIENT** with training and technical assistance on program-related matters; performing on-site reviews of the **SUBRECIPIENT's** program operations; and imposing additional reporting requirements and other compliance monitoring procedures.
- e. If the FRF Office, in consultation with OOC and the Administrative Oversight, determines that the **SUBRECIPIENT** poses a moderate or high risk for noncompliance with federal

laws, regulations, and the terms and conditions of this Agreement the NATION may require the following additional reporting:

- i. a detailed line-item expenditure report, with General Ledger detail, for the month reported;
 - ii. supporting documentation for any individual expenditure greater than twenty-five thousand dollars (\$25,000) incurred during the month reported; and
 - iii. a reconciliation of the Subaward Funds, starting with the beginning balance, cash received, disbursements to date, program income (if applicable), and ending balance.
- f. The **SUBRECIPIENT** may be required to attend a training on the eligible uses of the Subaward Funds based on past experience with managing federal awards programs or on the NATION'S risk assessment of the **SUBRECIPIENT**.
- g. If the **SUBRECIPIENT** fails to timely submit such required reports or if the **SUBRECIPIENT**'s reports show lack of progress and/or low expenditure, it shall be in default under this Agreement. The NATION shall not disburse any Subaward Funds until the required reports are submitted.
- h. The **SUBRECIPIENT** shall submit a final financial closeout report providing a final accounting of the uses of the Subaward Funds, which should be supported by documentation, including but not limited to receipts, invoices, contracts, listing of all property purchased with the Subaward Funds costing \$5,000 or more with an expected useful life of more than one year, and payroll records. This final report must be submitted the earlier of forty-five (45) days after September 30, 2026 unless an earlier or later date is determined by the NATION through a resolution of the Navajo Nation Council or a Standing Committee of Council or thirty (30) days after the completion of all projects within the scope of work of this Agreement. If, however, this Agreement is terminated, the final financial closeout report is due thirty (30) days after termination of the Agreement. If the Subaward Funds are being disbursed on a reimbursement basis according to the disbursement schedule attached as Appendix C, the NATION shall not release the final disbursement of Subaward Funds until the final financial closeout report is submitted to Administrative Oversight, the FRF Office, OOC, and OMB, and is reviewed and approved by OOC. If the **SUBRECIPIENT** fails to timely submit a final financial closeout report, it shall be in default on this Agreement and shall return the Subaward Funds in full to the NATION within fifteen (15) days following the reporting deadline. The **SUBRECIPIENT** shall be required to return these Subaward Funds without first receiving Notices of Default or Termination from the NATION.
- i. The **SUBRECIPIENT** shall keep detailed and accurate records of all expenditures and receipts related to this Agreement, and shall provide the NATION with any reporting summarizing actual expenditures, as requested by the FRF Office, OOC, or the Administrative Oversight, including but not limited to:
- i. Inventory listing of all property purchased with the Subaward Funds costing \$5,000 or more with an expected useful life of more than one year;
 - ii. Documentation that the costs incurred were fair and reasonable;
 - iii. Payroll records;
 - iv. General ledger;

- v. Cash disbursements journal;
- vi. Contracts and purchase orders with contractors and vendors;
- vii. Vendor invoices;
- viii. Expenditure reports; and
- ix. Debt agreements.

- j. The **SUBRECIPIENT** shall also assist the Administrative Oversight to prepare and present quarterly reports to its legislative oversight committee of the Navajo Nation Council in accordance with the requirement in Section 15 of CJN-29-22.
- k. All financial reporting and record keeping requirements shall survive the expiration and termination of this Agreement.

14. Single Audit.

- a. The Single Audit Act applies to the expenditure of Navajo Nation Fiscal Recovery Funds. **SUBRECIPIENT** shall have a Single Audit performed by an independent external auditor if it expends Seven Hundred and Fifty Thousand (\$750,000) or more dollars of federal funds in one fiscal year.
- b. **SUBRECIPIENT** can use the two (2%) percent administrative cost allocated in Section 10 of this Agreement to pay for the Single Audit.

15. The Nation's Right to Inspect Places of Business and to Inspect and Audit Books and Records.

- a. The **SUBRECIPIENT** agrees that the **NATION** may, at reasonable times, inspect the part of the plant or place of business and the project worksites of the **SUBRECIPIENT** that are related to the performance of this Agreement; and the **SUBRECIPIENT** further agrees that the **NATION** and its auditors, may at reasonable times and places, inspect and audit the **SUBRECIPIENT** books and records to the extent that such books and records relate to the performance of this Agreement. The **SUBRECIPIENT** shall maintain such books and records, and such books and records of any Subcontractor, for at least five (5) years after all Subaward Funds have been expended by the **SUBRECIPIENT** or returned to the **NATION**, or from the date of final payment under this Agreement, whichever is later.
- b. Further, the **SUBRECIPIENT** agrees to include in any Subcontractor agreement related to this Agreement, provisions that the Subcontractor agrees (i) that the **NATION** may, at reasonable times, inspect the part of the plant or place of business of the Subcontractor that is related to the performance of this Agreement; (ii) that the **NATION** may, at reasonable times and places, inspect and audit the Subcontractor's books and records to the extent that such books and records relate to the performance of this Agreement; and (iii) that the Subcontractor shall maintain its books and records related to the performance of this Agreement for at least five (5) years from the date of the **SUBRECIPIENT** final payment under this Agreement.

16. Reserved.

17. Evaluation and On-Site Inspection.

- a. **Progress Inspections.** The Administrative Oversight and the FRF Office will conduct periodic on-site monitoring to ensure efficient completion of the work.
- b. **Final Inspections.** Within ten (10) calendar days after completion of the project, the **SUBRECIPIENT** shall notify the Administrative Oversight and the FRF Office, in writing, of completion of the work. The **SUBRECIPIENT** and the Administrative Oversight and the FRF Office shall perform a final inspection no later than fifteen (15) days from the date the Administrative Oversight and the FRF Office receive the completion notice.

18. Assignment.

- a. The **SUBRECIPIENT** shall not assign or otherwise transfer its rights, nor delegate any of its obligations, under this Agreement without prior written approval from the **NATION**. This Agreement is for the exclusive benefit of the **SUBRECIPIENT** and the **NATION**, and not for the benefit of any third party, including without limitation, any owner, partner, board member, employee, or volunteer of the **SUBRECIPIENT**.
- b. The **SUBRECIPIENT** shall not use Subaward Funds to grant subawards to other entities.
- c. The **SUBRECIPIENT** shall not pledge nor otherwise assign any monies due under this Agreement or any claim arising thereunder, to any party or parties, bank, trust company or other financial institutions.
- d. The **SUBRECIPIENT** shall immediately provide written notification to the **NATION** of any changes in the **SUBRECIPIENT'S** size or structure that would affect the **SUBRECIPIENT'S** eligibility for or ability to manage the Subaward Funds; any circumstances preventing expenditure of Subaward Funds by the **SUBRECIPIENT** for the purposes described in this Agreement; or any expenditure using Subaward Funds made for any purpose other than those for which the Agreement is intended.

19. False Statements by Subrecipient.

By acceptance of this Agreement, the **SUBRECIPIENT** makes all the statements, representations, warranties, guarantees, certifications, and affirmations contained herein. If any of the statements, representations, warranties, guarantees, certifications, and affirmations are false or if the **SUBRECIPIENT** in any other way executes the Agreement including false statements, or it is subsequently determined that the **SUBRECIPIENT** has violated any of the statements, representations, warranties, guarantees, certifications, or affirmations included in this Agreement, the **NATION** may consider such an act a default under this Agreement and may terminate or void this Agreement for cause and pursue other remedies available to the **NATION** under this Agreement and all applicable laws.

20. Conflicts of Interest.

- a. Each **PARTY** warrants that there was no improper influence involved in the granting of the Subaward to the **SUBRECIPIENT**, and each **PARTY** further warrants that it did not and will not employ, retain, or contract with any person or entity on a contingent compensation basis for the purpose of seeking, obtaining, maintaining, or extending this Agreement. Each **PARTY** agrees, warrants, and represents that no gratuity whatsoever has been or will be

offered or conferred with a view towards obtaining, maintaining, or extending this Agreement.

- b. The officials and employees of the **PARTIES** shall not have any personal economic interest or special interest, direct or indirect, which gives rise to a conflict of interest or would otherwise violate the Navajo Nation Ethics in Government Law, 2 N.N.C. §§3741 *et. seq.*, with respect to this Agreement. The **SUBRECIPIENT** shall disclose in writing to the **NATION** any potential conflict of interest, as defined in the Ethics in Government Law, affecting the Subaward Funds. The **NATION** will review all disclosed potential conflicts of interest and may terminate this Agreement according to Article 28 of this Agreement.
- c. The **SUBRECIPIENT** understands and agrees it will maintain a conflict of interest policy consistent with 2 C.F.R. § 200.318(c) and that such policy is applicable to each activity funded under this Subaward. The **SUBRECIPIENT** shall disclose in writing to the **NATION** any potential conflict of interest affecting the Subaward Funds in accordance with 2 C.F.R. § 200.112. The **SUBRECIPIENT** will establish safeguards to prohibit its officers, agents, employees, and members from using their positions for a purpose that constitutes or presents the appearance of personal or organizational conflict of interest, self-dealing, or personal gain, whether for themselves or others, particularly those with whom they have family, business, or other ties. The **SUBRECIPIENT** will operate with complete independence and objectivity without potential, actual, or apparent conflict of interest with respect to its performance under this Agreement.

21. Fraud, Waste, and Abuse.

- a. The **SUBRECIPIENT** understands that the **NATION** will not tolerate any type of fraud, waste, abuse, or misuse ("misuse") of Subaward Funds received from the **NATION**. The **SUBRECIPIENT** understands and agrees that misuse of Subaward Funds shall be considered an act of default under this Agreement as grounds for the **NATION** to terminate this Agreement, and may further result in a range of penalties, including suspension of current and future funds; ineligibility for, suspension, or debarment from Navajo Nation contract opportunities; recoupment and offset of monies provided under an award; and civil and/or criminal penalties. In the event the **SUBRECIPIENT** becomes aware of any allegation or a finding of fraud, waste, or misuse of funds received from the **NATION** or made against the **SUBRECIPIENT**, the **SUBRECIPIENT** shall immediately notify the **NATION** of said allegation or finding and continue to inform the **NATION** of the status of any on-going investigations into the allegations or steps being taken to remedy the finding.
- b. In accordance with 41 U.S.C. § 4712, the **SUBRECIPIENT** shall provide protections for whistleblowers. The **SUBRECIPIENT** shall not discharge, demote, or discriminate against an employee in reprisal for disclosing to the **SUBRECIPIENT**, the **NATION**, or relevant federal authorities, evidence of gross mismanagement or waste of the Subaward, an abuse of authority relating to the Subaward, a substantial and specific danger to public health or safety, or a violation of law, rule, or regulation related to the Subaward.

22. Taxes.

The **SUBRECIPIENT** shall comply with all applicable Navajo Nation tax laws under Title 24 of the Navajo Nation Code and corresponding regulations as amended from time to time. The

SUBRECIPIENT'S contractor is subject to and shall be liable for payment of the Navajo Nation Sales Tax, at the prevailing rate, on gross receipts for all work performed within the territorial jurisdiction of the Navajo Nation pursuant to 24 N.N.C. § 601 *et seq.*, and the Navajo Nation Sales Tax Regulations § 6.101 *et seq.*, as amended from time to time, except that work performed within the To'Nanees'Dizi Local Government ("Tuba City Chapter") or the Kayenta Township is subject to their respective local sales taxes as amended from time to time. In addition to being subject to Navajo Nation Sales Tax, the **SUBRECIPIENT'S** contractor is subject to local sales tax on gross receipts for all work performed within a governance-certified chapter that imposes a local sales tax pursuant to a duly enacted local tax ordinance and the Uniform Local Tax Code, 24 N.N.C. § 150 *et seq.* The **SUBRECIPIENT'S** contractor is solely responsible for the payment of all applicable taxes related to this Agreement, and the **NATION** is not responsible for withholding or paying any income taxes, Federal Insurance Contributions Act (FICA) taxes, unemployment taxes, or any other taxes, from any payments owed to the **SUBRECIPIENT'S** contractor, nor shall the **NATION** be responsible for remitting the **SUBRECIPIENT'S** contractor share of employment taxes to the federal or any state governments.

23. Insurance Coverage.

The **SUBRECIPIENT** shall obtain and maintain adequate insurance coverage as recommended and verified by the Navajo Nation Risk Management Program ("RMP"). The **SUBRECIPIENT** shall provide its Verification of Insurance indicating they are in good standing with the Nation's insurance. The **SUBRECIPIENT** shall notify the Administrative Oversight, the FRF Office and the RMP, c/o The Navajo Nation, P.O. Box 1690, Window Rock, Arizona 86515 within five (5) days of any change in the insurance policy. Failure to fully comply with this provision shall render this Agreement voidable by the **NATION** discretion.

24. Modifications.

- a. The **NATION** and the **SUBRECIPIENT** may agree to modify the Agreement. Such modifications include, but are not limited to, modifying the Scope of Work, adding funds to previously un-awarded cost items or categories, changing funds in any awarded cost item or category, de-obligating awarded funds, or changing the **SUBRECIPIENT'S** Authorized Representative. The terms of any such modifications must be made in writing, and must be signed by both the **SUBRECIPIENT** and the **NATION** to take effect.
- b. Modifications must adhere to the requirements of Council Resolution CJN-29-22 and the Fiscal Recovery Fund Procedures set forth in the Budget and Finance Committee Resolution BFS-31-21. All modifications shall require review by the Department of Justice ("DOJ") for an initial eligibility determination and a determination of whether legislative approval of the modification is required. Certain modifications may require approval by the Navajo Nation Council or Committees of Council. For any modification that includes a modification of the Project's budget, a Budget Revision Request form, shall be completed by the **SUBRECIPIENT** and submitted first to the Authorized Representative and the FRF Office for review and then forwarded to DOJ for review and the OMB for approval.

25. Remedies for Non-Compliance.

- a. If the **NATION** determines that the **SUBRECIPIENT** materially fails to comply with any term of this Agreement, whether stated in a federal or Navajo Nation statute, regulation, an

assurance, legislation, a notice of award, or any other applicable requirement, the NATION will issue a Notice of Failure to Comply, of Suspension, or of Termination, and may take action, in its sole discretion, including but not limited to:

- i. Changing the NATION's risk assessment of the SUBRECIPIENT and requiring additional and more stringent reporting from the SUBRECIPIENT;
- ii. Placing liens on the SUBRECIPIENT's assets purchased with the Subaward Funds;
- iii. Temporarily withholding disbursements of Subaward Funds pending correction of the deficiency;
- iv. Disallowing or denying use of Subaward Funds for all or part of the cost of the activity or action not in compliance;
- v. Disallowing claims for reimbursement;
- vi. Wholly or partially suspending this Agreement;
- vii. Requiring return of previous disbursements of Subaward Funds;
- viii. Prohibiting the SUBRECIPIENT from applying for or receiving additional funds for other programs administered by the Navajo Nation until repayment to the NATION is made and any other compliance or audit finding is satisfactorily resolved;
- ix. Reducing the amount of the Subaward from the NATION;
- x. Imposing a Corrective Action Plan;
- xi. Withholding disbursements of future awards from the NATION, and deeming the SUBRECIPIENT to be ineligible for future business opportunities with the NATION, including but not limited to: awards; contracts; grants; leases; rights of way; licenses; loans, permits;
- xii. Offsetting future awards and payments to the SUBRECIPIENT;
- xiii. Terminating this Agreement; or
- xiv. Taking other enforcement action or remedies, including imposing sanctions without first requiring a Corrective Action Plan, or pursuing other legal remedies.

- b. The SUBRECIPIENT'S costs resulting from obligations incurred during a suspension or after termination of this Agreement will not be allowable unless the NATION expressly authorizes such costs in the Notice of Failure to Comply, of Suspension, or of Termination. Absent such express authorization, the SUBRECIPIENT shall return that portion of the Subaward Funds to the NATION.

26. Non-Waiver.

No failure on the part of the NATION to act, and no delay in exercising any right hereunder shall operate as a waiver thereof; nor shall any single or partial act or exercise by the NATION of any right hereunder preclude any other or further exercise thereof or the exercise of any other right. The remedies herein provided are cumulative and not exclusive of any remedy available to the NATION at law or in equity.

27. Expiration or Termination of the Agreement.

- a. The NATION may, at its sole discretion, terminate this Agreement for cause or convenience, without recourse, liability, or penalty against the NATION, upon Written Notice to the SUBRECIPIENT, without further notice to or opportunity to cure by the SUBRECIPIENT. Such notification of termination will be effective on the date of the notification, if no other

effective date is specified in the Notice of Termination;

- b. The **NATION** and the **SUBRECIPIENT** may mutually agree to terminate this Agreement. The **NATION** in its sole discretion will determine if, as part of the agreed termination, the **SUBRECIPIENT** is required to return any or all of the disbursed Subaward Funds within ten (10) business days of termination. This determination and its terms shall be communicated in writing to the **SUBRECIPIENT**;
- c. Termination is not an exclusive remedy for the **NATION**, but will be in addition to any other rights and remedies provided in equity, at law, or under this Agreement. Following termination by the **NATION**, the **SUBRECIPIENT** shall continue to be obligated to the **NATION** for an accounting of and the return of Subaward Funds in accordance with applicable provisions of this Agreement. In the event of termination under this Section, the **NATION's** obligation to reimburse the **SUBRECIPIENT** is limited to allowable costs incurred and paid by the **SUBRECIPIENT** prior to the effective date of termination, and any costs determined by the **NATION** in its sole discretion to be allowable, reasonable, and necessary for cost-effective wind up of the allocation.
- d. Termination of this Agreement for any reason, or expiration of this Agreement shall not release the **PARTIES** from any liability or obligation set forth in this Agreement that is expressly stated to survive any such termination or expiration. The rights and obligations pertaining to the allocation, close-out, cooperation, and provision of additional information, return of funds, audit rights, records retention, public information, and any other provision implying survivability shall remain in effect after the expiration or termination of this Agreement.

28. **Disputes.**

Any and all disputes arising under, related to, or in connection with this Agreement shall be resolved first through informal, good faith negotiation between the **PARTIES** under the laws of the Navajo Nation. The **PARTIES** shall use their best faith efforts to resolve any dispute informally and expeditiously through such negotiations at the staff level. Each **PARTY** shall designate a staff person to meet with the other **PARTY** at a mutually agreeable time and place. The **PARTIES** will honor all reasonable requests for relevant documents and information. If the dispute cannot be resolved within fifteen (15) business days, the **PARTIES** shall refer the matter to the Executive Director of DCD and the Chapter President, and shall consult with the Department of Justice, to assist with interpretation of this Agreement and applicable Navajo Nation laws and policies. If the **PARTIES** are unable to resolve the dispute, the **NATION** shall terminate this Agreement after consultation with the DOJ. The **SUBRECIPIENT** shall return any Grant Project Funds that are not Spent or Encumbered to the **NATION** pursuant to Section 7 of this Agreement.

29. **Applicable Law and Jurisdiction.**

- a. The **SUBRECIPIENT** shall comply with all Navajo Nation laws. Failure to comply with Navajo Nation law shall be an act of default, and grounds for termination of this Agreement by the **NATION**. The **SUBRECIPIENT** agrees to be subject to the jurisdiction of Navajo Nation courts and tribunals.

- b. This Agreement will be governed in all respects by the laws of the NATION, both as to interpretation and performance, without regard to conflicts of law or choice of law provisions. Any action arising out of or in connection with this Agreement may only be instituted and maintained in a Navajo Nation court.

30. Force Majeure.

Neither the SUBRECIPIENT, nor the NATION shall be required to perform any obligation under this Agreement or be liable or responsible for any loss or damage resulting from its failure to perform so long as performance is delayed by force majeure or acts of God, including but not limited to strikes, lockouts or labor shortages, embargo, riot, war, revolution, terrorism, rebellion, insurrection, flood, or natural disaster. For the purposes of this Agreement, COVID-19 shall not be considered a force majeure. The SUBRECIPIENT must inform the NATION of any force majeure events delaying performance of its obligations in writing, with proof of receipt of notice, within three (3) business days of the commencement of such force majeure or acts of God, or will otherwise waive this right as a defense.

31. No Obligation by Federal Government.

The PARTIES acknowledge and agree that the federal government is not a Party to this Agreement and is not subject to any obligations or liabilities to either Party, any third Party, or any subcontractor pertaining to any matter related to this Agreement.

32. Compliance with Federal Laws, Regulations, and Executive Orders.

- a. The SUBRECIPIENT will comply with all applicable federal laws, regulations, executive orders, policies, procedures, and directives, which may include but shall not be limited to: the Uniform Administrative Requirements, Cost Principles, and Audit Requirements for Federal Awards, 2 C.F.R. Part 200; Procurement Standards in 2 C.F.R. Part 200 Subpart D; and applicable legal requirements cited in 2 C.F.R. Part 200 Appendix II and the NATION's Financial Assistance Agreement with Treasury attached as Appendix F.
- b. The SUBRECIPIENT shall comply with all federal requirements in the ARPA; the Financial Assistance Agreement between Treasury and the NATION, identified as Appendix F; the CSLFRF Final Rule and other Treasury guidance in the form of Frequently Asked Questions; and the CSLFRF Compliance and Reporting Guidance, identified as Appendix G.
- c. For capital projects and infrastructure projects in excess of \$10 million, the SUBRECIPIENT will need to provide documentation of compliance with applicable wage and labor standards.
- d. Any publications produced with funds from this Subaward must display the following language: "This project [is being] [was] supported, in whole or in part, by federal award number 21.027 awarded to the Navajo Nation by the U.S. Department of the Treasury."

33. Certification Regarding Lobbying (2 CFR 200.450).

By signing this Agreement, the Authorized Representative certifies, to the best of his/her knowledge and belief, that no federally appropriated funds have been or will be paid, by or on behalf of the SUBRECIPIENT, to any person or entity for influencing or attempting to influence an officer or employee of any agency, a Member of Congress, an officer or employee of

Congress, or an employee of a Member of Congress in connection with the awarding of any federal contract, the making of any federal grant, the making of any federal loan, the entering into of any cooperative agreement, and the extension, continuation, renewal, amendment, or modification of any federal contract, grant, loan, or cooperative agreement in accordance with 2 CFR 200.450. If any funds other than federally appropriated funds have been paid or will be paid to any person or entity for influencing or intending to influence an officer or employee of any agency, a Member of Congress, an officer or employee of Congress, or an employee of a Member of Congress in connection with this federal contract, grant, loan, or cooperative agreement, the **SUBRECIPIENT** shall complete and submit Standard Form-LLL, Disclosure Form to Report Lobbying, to the **NATION**. This certification is a material representation of fact upon which reliance was placed when this transaction was made or entered into. Submission of this certification is a prerequisite for making or entering into this transaction imposed by 31 U.S.C. § 1352. Any person who fails to file the required certification shall be subject to a civil penalty of not less than \$10,000 and not more than \$100,000 for each such failure.

34. No Agency or Employment Relationship.

In its performance of work pursuant to this Agreement, the **SUBRECIPIENT**, unless it is a Navajo Nation Chapter or Township, shall be an independent entity from the **NATION**. The **SUBRECIPIENT** shall not be considered an employee or agent of the **NATION**. Nothing in this Agreement shall be construed to create any agency or employment relationship between the **SUBRECIPIENT** or any of its employees and the **NATION**. Neither Party shall have any right, power, or authority to assume, create, or incur any expense, liability, or obligation, whether express or implied, on behalf of the other Party. Nothing in this Agreement shall be construed to create any agency or employment relation between the **PARTIES**, and the **SUBRECIPIENT** is free to make its services available to third parties. The **SUBRECIPIENT** is not eligible to participate in, nor eligible for coverage under, any **NATION** employee benefit plan or offering.

35. Indemnification.

Except where the **SUBRECIPIENT** is another Navajo Nation Governmental Entity, such as a Chapter or Township, the **SUBRECIPIENT** agrees to hold harmless and indemnify the **NATION** against any and all losses, costs, damages, claims, accident or injury to person or property including death, attorneys' fees, expenses, and other liability whatsoever (collectively, "Claims"), arising under, related to, or in connection with this Agreement, except to the extent such Claims are directly caused by the gross negligence or wanton and willful conduct of the **NATION** or to the extent they result from the negligence of **NATION** officials or employees as provided for and in accordance with 1 N.N.C. § 551 *et seq.*

36. Rights of Other Parties.

Nothing in this Agreement shall be interpreted to create any rights in any third party that is not an entity or subdivision of the Navajo Nation government.

37. Conflicting and Additional Terms.

All additional terms and conditions of the **SUBRECIPIENT** are attached hereto and incorporated into this Agreement, provided however that in the event of any conflict between these Terms and Conditions and any additional terms and conditions offered by the **SUBRECIPIENT**, these Terms and Conditions shall control and govern. Any additional terms and conditions not attached to this Agreement shall have no force or effect.

38. **Severability.**

If any provision of this Agreement is held invalid by the Courts of the NATION, all remaining provisions which can be implemented shall remain in force and be given full force and effect.

IN WITNESS WHEREOF, we the undersigned hereby execute this Agreement:

For the SUBRECIPIENT:

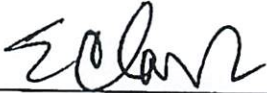

Chapter President
Elmer Clark
PO Box 7385, Winslow, AZ 86047

1/17/2024
Date

For THE NAVAJO NATION:



Buu Nygren, President
The Navajo Nation
Window Rock, AZ 86515

2/22/2024
Date

Appendix A

Scope of Work

John Deere 324 G With Forklifts (6.1)

SCOPE OF WORK

PROJECT TITLE: John Deere 324G with JRB 48FORKS – Forklift **DATE:** August 11, 2023

PROJECT LOCATION: Navajo Nation- Teesto Chapter

CONTRACTOR/VENDOR: RDO Equipment Co., 5500 East Penstock Avenue, Flagstaff, Arizona 86004

=====

PROJECT DESCRIPTION and PROJECT INTRODUCTION:

The purchase of John Deere 324G with JRB 48FORKS - Forklift heavy equipment will be utilized to unload and load bulk orders for community needs, goods and service.

SCOPE OF WORK: (See attachment)
John Deere 324G with JRB 48FORKS – Forklift

- 00C2T 324G SKID STEER
- 0722 Open ROPS, Manual QT, SL, 2Spd
- 1301 Engine - Turbocharged 8050 Cold Start Package
- 8060 Engine Air Precleaner
- 1501 English Operator's Manual and Decals
- 170K JDLink™
- 2315 12 X 16.5 NHS, CAMSO SKS
- 0950 E-H (ISO Pattern) Joystick Controls
- 6001 Mechanical Suspension Seat (Vinyl)
- 4000 2-Inch Seat Belt
- 8380 Footrest with Floormat
- 9041 72 in. Construction Bucket (17.8 cu. ft.) with Edge
- 2021 ARROW MATERIAL HANDLING PRODUCTS FORKS48 1.5X4X48 48" FORK TINES
PRODUCTS FORKS48



Investment Proposal (Quote)

RDO Equipment Co.
 5500 East Penstock Avenue
 Flagstaff AZ, 86004
 Phone: (928) 526-0639 - Fax: (928) 526-2498

Proposal for:
 TEESTO CHAPTER OF THE NAV
 PO BOX 7385
 WINSLOW, AZ, 860477166
 NAVAJO

Investment Proposal Date: 5/8/2023
 Pricing Valid Until: 5/22/2023
 Deal Number: 1619003
 Customer Account#: 8042005
 Sales Professional: Buzz Ivicsek
 Phone: (928) 526-0639
 Fax: (928) 526-2498
 Email: Blvick@rdoequipment.com

Comments

POSSIBLE 3-5% PRICE INCREASE WITHIN THE NEXT 3-6 MONTHS.

Equipment Information

Quantity	Serial Number Stock Number	Hours (approx.)	Status / Year / Make / Model Additional Items	Cash Price
1	TBD TBD	0	New 2023 JOHN DEERE 324G	\$78,800.00
			Customer Discount SOURCEWELL 30%	(\$21,598.50)
			Item Subtotal:	\$57,201.50
1	82997 X486666	0	Attachment - New 2021 ARROW MATERIAL HANDLING PRODUCTS FORKS48	\$960.00
			Equipment Subtotal:	\$58,161.50

Purchase Order Totals

Balance: \$58,161.50
 AZ STATE TAX: \$3,489.69
 AZ COUNTY TAX: \$0.00
 AZ CITY TAX: \$0.00
 Sales Tax Total: \$3,489.69
 Sub Total: \$61,651.19
 Cash with Order: \$0.00
 Balance Due: \$61,651.19

Equipment Options

Qty	Serial Number	Year / Make / Model	Description
1	TBD	2023 JOHN DEERE 324G	00C2T 324G SKID STEER 0722 Open ROPS, Manual QT, SL, 2Spd 1301 Engine - Turbocharged 8050 Cold Start Package 8060 Engine Air Precleaner 1501 English Operator's Manual and Decals 170K JDLINK™ 2315 12 X 16.5 NHS, CAMSO SKS 0950 E-H (ISO Pattern) Joystick Controls 6001 Mechanical Suspension Seat (Vinyl) 4000 2-Inch Seat Belt 8380 Footrest with Floormat 9041 72 in. Construction Bucket (17.8 cu. ft.) with Edge
1	82997	2021 ARROW MATERIAL HANDLING PRODUCTS FORKS48	1.5X4X48 48" FORK TINES



reported to an authorized John Deere dealer within 90 days of installation or before expiration of the applicable Standard Warranty, Factory-Installed Undercarriage Warranty and/or StructurALL Warranty whichever is later.

H. TELEMATICS

NOTICE: Products may be equipped with telematics hardware and software ("Telematics") that transmit data to John Deere/ Dealer. Purchaser may deactivate Telematics at www.idlink.com.

Notwithstanding Purchaser's right, title or interest in the Products, Purchaser agrees that John Deere and Dealer (their affiliates, successors and assigns), without further notice to Purchaser have the right to:

1. Access, use, collect and disclose any data generated by, collected by, or stored in, Products or any hardware or devices interfacing with Products ("Machine Data");
2. Access Machine Data directly through data reporting devices integrated within, or attached to, Products, including Telematics ("Data Reporting Systems"); and
3. Update the Data Reporting Systems software from time to time. Machine Data will only be used in accordance with John Deere's Machine Data Policy, located at www.JohnDeere.com/MachineDataPolicy.

I. OBTAINING WARRANTY SERVICE -

To obtain warranty service, the purchaser must request warranty service from a John Deere dealer authorized to sell the product to be serviced. When making such a request, the purchaser must present evidence of the product's delivery date, make the product available at the dealer's place of business, and inform the dealer in what way the purchaser believes the product to be defective. Standard Warranty, Factory-Installed Undercarriage Warranty and/or StructurALL Warranty repairs may be made in the field if the purchaser and servicing dealer so desire. However, John Deere will not be responsible for any charges (such as dealer travel time, mileage or extra labor/labour) that would not have been incurred had the product been repaired at the dealer's place of business.

J. NO IMPLIED WARRANTY, CONDITIONS OR OTHER REPRESENTATION -

Where permitted by law, neither John Deere nor any company affiliated with it makes any warranties, representations, conditions or promises, express or implied, as to the quality, performance, or freedom from defect of its products, other than those set forth in this document and **NO IMPLIED WARRANTY OF MERCHANTABILITY, CONDITIONS OR FITNESS IS MADE.**

K. NO DEALER WARRANTY -

The selling dealer makes no warranty of its own on any item covered by this warranty, and makes no warranty on other items unless the dealer delivers to the purchaser a separate written warranty certificate specifically warranting the item. **The dealer has no authority to make any representation or promise on behalf of John Deere, or to modify the terms or limitations of this warranty in any way.**

L. USED JOHN DEERE PRODUCTS ONLY -

John Deere will transfer remaining Standard Warranty, Factory-Installed Undercarriage Warranty and/or StructurALL Warranty to the purchaser of a used John Deere construction and/or forestry product that has been used for less than the full warranty period provided at the product's original retail purchase. This transfer is not effective until change of ownership is registered by a John Deere dealer. **ALL THE TERMS, INCLUDING LIMITATIONS AND EXCLUSIONS, OF THE JOHN DEERE STANDARD WARRANTY, FACTORY-INSTALLED UNDERCARRIAGE WARRANTY, AND/OR STRUCTURALL WARRANTY ORIGINALLY PROVIDED FOR THE PRODUCT REMAIN IN EFFECT AND APPLICABLE.**

. ITEMS NOT COVERED -

John Deere is NOT responsible for the following:

1. Freight
2. Adjustments to compensate for wear, for periodic maintenance or adjustments that result from normal wear and tear.
3. Damage caused by unapproved adjustments (electronic or mechanical) to machine or machine components outside of published specifications including but not limited to engine, hydraulic components and relief valves.
4. Program updates, calibrations, and pressure adjustments.
5. Diagnostic Time
6. Additional Labor/Labour Time - Above SPG/Labor/Labour Rate
7. Additional Cleaning - Above SPG/Labor/Labour Rate
8. Rental Fees
9. Depreciation or damage caused by normal wear or application, lack of reasonable and proper maintenance, failure to follow operating instructions, misuse, negligence, collision or other accidents.
10. Premiums charged for Overtime Labor/Labour
11. Transportation to and from the dealership.
12. Travel time, mileage or service calls by the dealer.
13. Non-John Deere components or modifications, Rotobec grapples, and attachments installed aftermarket.
14. Shop supplies and maintenance items such as, but not limited to: filters, fuels, oil, hydraulic fluid, lubricants, coolants, conditioners, shop towels, cleaners and degreasers. Note: Reimbursement for refills of oils/coolants lost due to a warrantable failure is covered when a system failure occurs outside the boundaries of a normal oil change (within 25% of specified change interval as provided in the Operator's Manual).
15. Torn, cut, or worn hoses.
16. Wear items, such as, but not limited to: body liner, belts, blades, bulbs, lubricated joints (including pins and bushings), dry brakes, brake linings, dry clutch linings, saw blades, chains, skidder grapple shocks, color marking nozzles, and articulation bumpers.
17. Items such as cutting-edge parts, delimiting knives, bucket teeth and rubber track are not warranted for depreciation or damage caused by normal wear, lack of proper maintenance, misuse, failure to follow operating instructions, the elements or accident.
18. Any defect in a non-covered component, or damage to or failure of a covered component caused by a defect in a non-covered component.
19. Secondary damage which occurs from continued operation of a product after recognition of the occurrence of a failure.
20. Parts supplied or modifications done by third party suppliers.
21. Topping off fluids when fluid levels fall in the range between low and full
22. Parts/Kits not ordered on machine and installed aftermarket. These parts will be covered by any applicable parts warranty.
23. Attachments installed aftermarket – i.e. Winch not installed at factory.
24. Custom options installed outside the factory – i.e. G.R. Manufacturing option packages.
25. Used Products (except as otherwise provided in section L below).

F. TERMINATION OF WARRANTY-

John Deere is relieved of its obligations under Standard Warranty, StructurALL Warranty, Factory-Installed Undercarriage Warranty and/or Extended Warranty if:

1. Service (other than normal maintenance and replacement of service items) is performed by someone other than an authorized John Deere dealer; or
2. The product is modified or altered in ways not approved by John Deere; or
3. Any unapproved or improperly sized attachment is installed on the product. Approval and attachment size shall be at John Deere's sole discretion. (Consult dealer prior to installing attachments or product modification).
4. The product is moved outside the US and/or Canada.

G. PARTS REPLACED UNDER WARRANTY -

Only new or remanufactured parts or components furnished or approved by John Deere, will be used if John Deere elects to repair the product. If any such part or component is defective in material or workmanship when installed in the product, John Deere will repair or replace, as it elects, such defective part or component, provided the defect is

person, whether based upon contract, tort, strict liability, or otherwise. This limitation does not apply to claims for personal injury.

J. ITEMS COVERED SEPARATELY -

1. **Standard Warranty** does not apply to batteries, radios, tires, cameras, or to Cummins, MTU or Detroit Diesel Engines installed in John Deere products, which are covered by separate written warranties.
2. **Factory-Installed Undercarriage Warranty** covers all non-rubberized factory-installed undercarriage wear components for 3 years or 4,000 hours from the date of delivery to the original retail purchaser, whichever occurs first (unless terminated earlier under Section F, below). For purposes of this warranty, a product that has been rented, used for demonstration purposes for 150 or more hours, or otherwise used prior to its original retail purchase has been "used" for the total duration of such use. In addition to the items listed in section E below, **Factory-Installed Undercarriage Warranty** does not cover: failures due to wear, machine application, maintenance practices, or improper machine configuration; removal and installation labor/labour; transportation or hauling costs; unapproved parts; non-wear items; and rubberized undercarriage components such as rubber tracks. **Warranty claims will be pro-rated based upon wear of the failed component and whether track shoe width is approved by John Deere. Factory-Installed Undercarriage Warranty does not apply to Scraper Tractors.**
3. **StructurALL Warranty** for new John Deere Products (except Compact Excavators & Loaders, Skid-Steer Loaders, Compact Track Loaders, Scraper Tractors, Pull-Type Scrapers, and Forestry Attachments, which are not eligible for **StructurALL Warranty**) begins at the date of delivery to the original retail purchaser and ends (unless terminated earlier under Section F, below) after three (3) years, or 10,000 hours (whichever occurs first). For purposes of this warranty, a product that has been rented, used for demonstration purposes for 150 or more hours, or otherwise used prior to its original retail purchase has been "used" for the total duration of such use. **StructurALL Warranty applies only to the following structural components listed below as installed on the product at the time of original manufacture. If a particular component is not listed below it is not covered by StructurALL Warranty.**

Arm; Articulation Joint (incl. pins & bushings); Bin Frame; Boom; Carbody; C-Frame*; Circle Frame; Coupler (John Deere built ONLY); Dipperstick; Draft Frame; Engine Frame; Equipment Frame; Grapple Arch and Grapple Boom; Loader Arm; Loader Frame; Mainframe; Moldboard Lift Arm; NeverGrease™ Pin Joints [Includes steering pin and bushing joints (standard equipment), roller elements (roller bearings) in bucket to boom joints and sliding elements (bushing) for boom and linkage joints (optional equipment)]; Rollover Protection Structure (ROPS); Side Frame; Swing Frame; Track Frame; Undercarriage Frame; X-Frame; Z-bar loader linkage (including bell crank and bucket driver link); Specialty booms and arms marketed as "heavy duty" by John Deere.

Items Covered by StructurALL for Cut-to-Length Forestry Machines: Front frame (welded assembly); Rear frame (welded assembly); Crane king post with basement; Middle joint frame; Cabin swing frame; Main Boom

StructurALL Warranty does not apply to:

1. Any product used primarily in extreme duty or severe duty applications such as but not limited to: demolition and wrecking, chemical plant (including fertilizer plants), salt mines, steel mill, land fill and transfer stations, scrap handling, scarifying and other applications that are similarly destructive or similarly heavy duty except specialty booms and arms as stated in Section D.3 above.
2. C-Frames on H-Series & J-Series Crawlers equipped with root rakes or used in forestry applications unless equipped with an "extreme duty" reinforcement package.
3. Cut-to-Length Forestry Heads and Slash Bundler Units.
4. Crawlers equipped with optional side booms.
5. Cut-to-Length Forestry, Excavator, and Log Loader swing bearings.
6. Motor Graders equipped with front- or rear-mounted snow wings.

STANDARD WARRANTY FOR NEW JOHN DEERE CONSTRUCTION, UTILITY, CCE AND FORESTRY PRODUCTS – US & Canada

Construction, Forestry & Compact Construction Equipment (CCE) Products*: 12 months Full Machine Standard Warranty

- *** Compact Construction Equipment Products Delivered and settled on or after 01 June 2018: 24 months or 2000 hours (whichever comes first) Full Machine Standard Warranty**
- **C&E Series Pull-Type Scrapers: 6 months Full Machine Standard Warranty**
- **DC & DE Series Pull-Type Scrapers: 12 months Full Machine Standard Warranty**
- **Scraper Tractors: 24 Months or 2000 Hours (whichever occurs first) Full Machine Standard Warranty**
- **Forestry Attachments: 12 Months or 2000 Hours (whichever occurs first) Full Machine Standard Warranty**
- **Frontier Equipment: 6 months Full Machine Standard Warranty (90 days in rental applications)**

The "Standard Warranty" is part of the warranty protection package available from John Deere Construction & Forestry Company (John Deere Limited in Canada) ("John Deere") to purchasers of new John Deere products ("product"):

STANDARD Warranty is John Deere's standard new product warranty, described in this document, provided at no additional charge to the purchaser.

EXTENDED Warranty is a separate repair contract made available by John Deere for purchasers who wish to complement their Standard Warranty coverage. Complete Extended Warranty details, including coverage options and limitations, are set forth in the Application for Extended Warranty, which is available from authorized John Deere dealers.

STRUCTURAL Warranty applies to certain structural components as listed below and as described in this document.

FACTORY-INSTALLED UNDERCARRIAGE Warranty applies to certain undercarriage components as listed below and as described in this document.

STANDARD WARRANTY - GENERAL PROVISIONS

John Deere will repair or replace, at its option, any parts (except those specified below) of a new John Deere product that, as delivered to the original retail purchaser(s), are defective in material or workmanship. Performance of this warranty will be free of charge for parts and labor/labour, except as otherwise stated below. Standard Warranty applies only to purchases from John Deere and authorized John Deere dealers and, except as otherwise provided in the next sentence and section L below, is extended only to the original retail purchaser of the product. Remaining Standard Warranty applicable to a used John Deere product is transferred to a subsequent purchaser of the product only if the subsequent purchaser requests a transfer from an authorized John Deere dealer before the product's Standard Warranty expires. Coverage begins on the date of delivery of the product to the original retail purchaser. For purposes of this warranty, a product that has been rented, used for demonstration purposes for 150 or more hours, or otherwise used prior to its original retail purchase has been "used" for the total duration of such use. Warranty statements required by law covering engine emissions-related parts and components are found on a separate written warranty certificate provided to the purchaser at the time of the original retail purchase.

B. WHAT IS COVERED BY STANDARD WARRANTY -

All parts of a new John Deere product (except those noted in Sections D and E below) are covered during the Standard Warranty period set out above.

C. EXCLUSIVE REMEDY -

The repair or replacement of covered parts or components that are defective, as provided in Sections A, B, D.2 and D.3 herein, shall be the purchaser's exclusive remedy for any defect in the product. However, if after repeated attempts such repair or replacement fails to correct the performance problem caused by the defect, the purchaser's sole remedy shall be a refund of the amount paid for the product (in exchange for a return of the product), excluding any transportation charges, license fees, taxes and insurance premiums, and less a reasonable allowance for use of the product prior to its return. In no event will the dealer, John Deere or any company affiliated with John Deere be liable for any incidental or consequential damages, including but not limited to loss of profits, rental of substitute equipment or other commercial loss. Correction of defects in the manner provided above shall constitute fulfillment of all liabilities of the Dealer, John Deere, or any company affiliated with John Deere to the purchaser or any other

John Deere 724P (6.1)

SCOPE OF WORK

PROJECT TITLE: John Deere 724P Front End Loader

DATE: August 11, 2023

PROJECT LOCATION: Navajo Nation- Teesto Chapter

CONTRACTOR/VENDOR: RDO Equipment Co., 5500 East Penstock Avenue, Flagstaff, Arizona 86004

=====

PROJECT DESCRIPTION and PROJECT INTRODUCTION:

The purchase of John Deere 724P Front End Loader heavy equipment will be utilized to removing soil, debris, clear, grade soil for graveside and making road passable for any emergency services, such as police vehicle, ambulance, and medical transports.

SCOPE OF WORK: (See attachment)

John Deere 724P Front End Loader

6071DW 724 P Wheel Loader

0202 United States

0259 English

0351 Translated Text Labels

0400 Standard Loader

0451 Standard Z-BAR

0614 Level 1 Trim

0658 Level 3 Performance

8505 Guards - Transmission & Bottom

8502 Maintenance and Service Package

8508 Auxiliary Equipment Package

0951 Rear Camera (Primary Display)

1100 Less Detection System

1602 Steering Wheel

1301 Left Side Steps 183E JDLink™

2201 Less Payload Scale w/ Cycle Counter

4067 John Deere 9.0L - FT4/SV

6522 Rear Counterweight & Rear Hitch w/ Pin

7026 Joystick Controls

7054 Three Function Hydraulics

5125 Bridgestone VJT - 23.5R25 L3 1-Star Radial Tires w/ 3 PC Rims

5553 Full Coverage Front Fenders 7402 Hydraulic Coupler - JRB 418 Pattern

7807 4.75 YD (3.63 CM) Enhanced Performance

7458 Bolt-On Cutting Edge

7502 76 Inch (1930mm) Wide Fork Frame

7703 72 Inch (1829mm) Construction Tines



JOHN DEERE

Investment Proposal (Quote)

RDO Equipment Co.
5500 East Penstock Avenue
Flagstaff AZ, 86004
Phone: (928) 526-0639 - Fax: (928) 526-2498

Proposal for:
TEESTO CHAPTER OF THE NAV
PO BOX 7385
WINSLOW, AZ, 860477166
NAVAJO

Investment Proposal Date: 1/3/2024
Pricing Valid Until: 2/2/2024
Deal Number: 1731973
Customer Account#: 8042005
Sales Professional: Buzz Ivicsek
Phone: (928) 526-0639
Fax: (928) 526-2498
Email: Blvicek@rdoequipment.com

Equipment Information

Quantity	Serial Number Stock Number	Hours (approx.)	Status / Year / Make / Model Additional Items	Cash Price
1	TBD TBD	0	New 2024 JOHN DEERE 724P	\$522,909.00
			Customer Discount SOURCEWELL NAVAJO NATION CONTRACT #5795 35%	(\$183,018.15)
			Freight in FACTORY FREIGHT	\$15,100.00
			Freight Out DELIVERY	\$4,840.00
			Prep / Reconditioning PRE-DELIVERY	\$5,700.00
			Warranty -John Deere Comprehensive-36 Months, 3000 Hours,Deductible: 200, Exp Date: 1/3/2027	\$5,454.00
			Item Subtotal:	\$370,984.85
			Equipment Subtotal:	\$370,984.85

Purchase Order Totals

Balance:	\$370,984.85
AZ STATE TAX:	\$22,259.09
AZ COUNTY TAX:	\$0.00
AZ CITY TAX:	\$0.00
Sales Tax Total:	\$22,259.09
Sub Total:	\$393,243.94
Cash with Order:	\$0.00
Balance Due:	\$393,243.94

Equipment Options

Qty	Serial Number	Year / Make / Model	Description
1	TBD	2024 JOHN DEERE 724P	6071DW 724 P Wheel Loader 0202 United States 0259 English 0351 Translated Text Labels 0400 Standard Loader 0451 Standard Z-BAR 0614 Level 1 Trim 0658 Level 3 Performance 8505 Guards - Transmission & Bottom 8502 Maintenance and Service Package 0951 Rear Camera (Primary Display) 1100 Less Detection System 1602 Steering Wheel 1301 Left Side Steps 183E JDLink™ 2201 Less Payload Scale w/ Cycle Counter 4067 John Deere 9.0L - FT4/SV 6522 Rear Counterweight & Rear Hitch w/ Pin 7026 Joystick Controls 7054 Three Function Hydraulics 5125 Bridgestone VJT - 23.5R25 L3 1-Star Radial Tires w/ 3 PC Rims 5553 Full Coverage Front Fenders 7402 Hydraulic Coupler - JRB 418 Pattern 7807 4.75 YD (3.63 CM) Enhanced Performance 7458 Bolt-On Cutting Edge 7502 76 Inch (1930mm) Wide Fork Frame 7703 72 Inch (1829mm) Construction Tines



Investment Proposal (Quote)

RDO Equipment Co.
 5500 East Penstock Avenue
 Flagstaff AZ, 86004
 Phone: (928) 526-0639 - Fax: (928) 526-2498

Proposal for:
 TEESTO CHAPTER OF THE NAV
 PO BOX 7385
 WINSLOW, AZ, 860477166
 NAVAJO

Investment Proposal Date: 1/3/2024
 Pricing Valid Until: 2/2/2024
 Deal Number: 1732021
 Customer Account#: 8042005
 Sales Professional: Buzz Ivicsek
 Phone: (928) 526-0639
 Fax: (928) 526-2498
 Email: Blvicek@rdoequipment.com

Equipment Information

Quantity	Serial Number Stock Number	Hours (approx.)	Status / Year / Make / Model Additional Items	Cash Price
1	TBD TBD	0	New 2024 JOHN DEERE 324G	\$72,873.00
			Customer Discount SOURCEWELL NAVAJO NATION CONTRACT #5795 30%	(\$21,861.90)
			Freight in FACTORY FREIGHT	\$3,280.00
			Freight Out DELIVERY	\$2,077.00
			Prep / Reconditioning PRE-DELIVERY	\$1,960.00
			Item Subtotal:	\$58,328.10
1	639894 X487284	0	Attachment - New 2021 JRB FORKS48	\$1,250.00
			Equipment Subtotal:	\$59,578.10

Purchase Order Totals

Balance: \$59,578.10
 AZ STATE TAX: \$3,574.69
 AZ COUNTY TAX: \$0.00
 AZ CITY TAX: \$0.00
 Sales Tax Total: \$3,574.69
 Sub Total: \$63,152.79
 Cash with Order: \$0.00
 Balance Due: \$63,152.79

Equipment Options

Qty	Serial Number	Year / Make / Model	Description
1	TBD	2024 JOHN DEERE 324G	00C2T 324G SKID STEER 0722 Open ROPS, Manual QT, SL, 2Spd 1301 Engine - Turbocharged 8050 Cold Start Package 8060 Engine Air Precleaner 1501 English Operator's Manual and Decals 170K JDLink™ 2315 12 X 16.5 NHS, CAMSO SKS 0950 E-H (ISO Pattern) Joystick Controls 6001 Mechanical Suspension Seat (Vinyl) 4000 2-Inch Seat Belt 8380 Footrest with Floormat 9041 72 in Construction Bucket (17.8 cu ft) w/ Edge 8305 Counterweight, (Double Set)
1	639894	2021 JRB FORKS48	67604 48" TINES

GSE RENTALS,LLC.

Rv.2 SP23-103

January 5, 2024

Teesto Chapter
P.O. Box 7385
Winslow, AZ 86047

Attention: Clara Tsosie

Subject: Teesto Chapter
RE: Quote for heavy equipment

Quote for the following heavy equipment per Ms. Clara Tsosie's request. Cost includes delivery.

QTY	DESCRIPTION	EX. PRICE
1	Caterpillar Loader 950GS	\$ 326,000.00
1	6K CAT Telehandler 32ft reach 6,000lbs	\$ 120,000.00

Sub-Total: \$ 446,000.00
NN Sales Tax 6%: \$ 26,760.00
TOTAL: \$ 472,760.00

Any questions please contact me at (480)650-1507.

Regards,
GSE Rentals

Kevin Johnson

Kevin Johnson
Sales Rep.

Acceptance of work as outlined above: (please print & sign name)

Name/Title: _____

Signature: _____

Date: _____

GSE RENTALS P.O. BOX 3208 FLAGSTAFF, AZ 86003
NN PRIORITY #1 PH: (480)650-1507 FAX: (602)237-9438

Equipment Options

Qty	Serial Number	Year / Make / Model	Description
1	TBD	2022 JOHN DEERE 724P	6070DW 724 P WHEEL LOADER 2605 English Decals and Manuals 1010 Standard Wheel Loader 0924 John Deere PowerTech Engine 1520 Automatic Reversing Hydraulic Fan 1430 Engine Air Intake System with Centrifugal Precleaner 1310 Flat Black Curved Stack 1610 Standard Fuel Filter with Water Separator and Standard Fuel Fill 1217 140 amp Alternator 2715 15 Amp Converter 7120 Halogen Work and Drive Lights 1120 5-Speed Powershift Transmission with Lock-up Torque Converter 3046 Front Hydraulically Locking Differential and Rear Conventional Differential Axles 3120 Manual Axle Differential Lock 2010 Standard Z-BAR 2360 Joystick Controls 2403 Three Function Hydraulics 1975 Hydrau XR Hydraulic Fluid 1905 Standard Cab 8450 Cab with Air A/C Charge 2240 Premium Seat, Heated and Ventilated with Heavy Duty Air Suspension 1945 7 inch Monitor with Dedicated Rear Camera Display 8310 Standard Exterior Mirrors 8360 Standard Radio 8240 Rear Camera 8275 LED Strobe Beacon with Left Beacon Bracket 5610 Left Side Steps Only 2120 Steering Wheel Only 2890 No Payload Scale without Cycle Counter 170K JDLink™ 5540 Full Width Front Fenders 4935 No Brand Preferred, 23.5R25 L3 Single Star Radial On 3pc. Rims 5320 Less Tire Pressure Monitoring System 9710 23.5R25 L3 Single Star No Brand Preferred Radial On 3pc. Rims 8559 Hydraulic Coupler - JRB 418 Pattern 8937 4.25 Cu. Yd. Bucket 8860 Bolt-on Cutting Edge 5770 76 in (1930mm) Wide Fork Frame, Floating Tine 5895 72 in (1829mm) Construction Tines 8220 Rear Hitch and Counterweight

STANDARD WARRANTY FOR NEW JOHN DEERE CONSTRUCTION, UTILITY, CCE AND FORESTRY PRODUCTS – US & Canada

- **Construction, Forestry & Compact Construction Equipment (CCE) Products***: 12 months Full Machine Standard Warranty
- *** Compact Construction Equipment Products Delivered and settled on or after 01 June 2018**: 24 months or 2000 hours (whichever comes first) Full Machine Standard Warranty
- **C&E Series Pull-Type Scrapers**: 6 months Full Machine Standard Warranty
- **DC & DE Series Pull-Type Scrapers**: 12 months Full Machine Standard Warranty
- **Scraper Tractors**: 24 Months or 2000 Hours (whichever occurs first) Full Machine Standard Warranty
- **Forestry Attachments**: 12 Months or 2000 Hours (whichever occurs first) Full Machine Standard Warranty
- **Frontier Equipment**: 6 months Full Machine Standard Warranty (90 days in rental applications)

The "Standard Warranty" is part of the warranty protection package available from John Deere Construction & Forestry Company (John Deere Limited in Canada) ("John Deere") to purchasers of new John Deere products ("product"):

STANDARD Warranty is John Deere's standard new product warranty, described in this document, provided at no additional charge to the purchaser.

EXTENDED Warranty is a separate repair contract made available by John Deere for purchasers who wish to complement their Standard Warranty coverage. Complete Extended Warranty details, including coverage options and limitations, are set forth in the Application for Extended Warranty, which is available from authorized John Deere dealers.

STRUCTURAL Warranty applies to certain structural components as listed below and as described in this document.

FACTORY-INSTALLED UNDERCARRIAGE Warranty applies to certain undercarriage components as listed below and as described in this document.

A. STANDARD WARRANTY - GENERAL PROVISIONS

John Deere will repair or replace, at its option, any parts (except those specified below) of a new John Deere product that, as delivered to the original retail purchaser(s), are defective in material or workmanship. Performance of this warranty will be free of charge for parts and labor/labour, except as otherwise stated below. Standard Warranty applies only to purchases from John Deere and authorized John Deere dealers and, except as otherwise provided in the next sentence and section L below, is extended only to the original retail purchaser of the product. Remaining Standard Warranty applicable to a used John Deere product is transferred to a subsequent purchaser of the product only if the subsequent purchaser requests a transfer from an authorized John Deere dealer before the product's Standard Warranty expires. Coverage begins on the date of delivery of the product to the original retail purchaser. For purposes of this warranty, a product that has been rented, used for demonstration purposes for 150 or more hours, or otherwise used prior to its original retail purchase has been "used" for the total duration of such use. Warranty statements required by law covering engine emissions-related parts and components are found on a separate written warranty certificate provided to the purchaser at the time of the original retail purchase.

B. WHAT IS COVERED BY STANDARD WARRANTY -

All parts of a new John Deere product (except those noted in Sections D and E below) are covered during the Standard Warranty period set out above.

C. EXCLUSIVE REMEDY -

The repair or replacement of covered parts or components that are defective, as provided in Sections A, B, D.2 and D.3 herein, shall be the purchaser's exclusive remedy for any defect in the product. However, if after repeated attempts such repair or replacement fails to correct the performance problem caused by the defect, the purchaser's sole remedy shall be a refund of the amount paid for the product (in exchange for a return of the product), excluding any transportation charges, license fees, taxes and insurance premiums, and less a reasonable allowance for use of the product prior to its return. In no event will the dealer, John Deere or any company affiliated with John Deere be liable for any incidental or consequential damages, including but not limited to loss of profits, rental of substitute equipment or other commercial loss. Correction of defects in the manner provided above shall constitute fulfillment of all liabilities of the Dealer, John Deere, or any company affiliated with John Deere to the purchaser or any other

person, whether based upon contract, tort, strict liability, or otherwise. This limitation does not apply to claims for personal injury.

D. ITEMS COVERED SEPARATELY -

1. **Standard Warranty** does not apply to batteries, radios, tires, cameras, or to Cummins, MTU or Detroit Diesel Engines installed in John Deere products, which are covered by separate written warranties.
2. **Factory-Installed Undercarriage Warranty** covers all non-rubberized factory-installed undercarriage wear components for 3 years or 4,000 hours from the date of delivery to the original retail purchaser, whichever occurs first (unless terminated earlier under Section F, below). For purposes of this warranty, a product that has been rented, used for demonstration purposes for 150 or more hours, or otherwise used prior to its original retail purchase has been "used" for the total duration of such use. In addition to the items listed in section E below, **Factory-Installed Undercarriage Warranty** does not cover: failures due to wear, machine application, maintenance practices, or improper machine configuration; removal and installation labor/labour; transportation or hauling costs; unapproved parts; non-wear items; and rubberized undercarriage components such as rubber tracks. **Warranty claims will be pro-rated based upon wear of the failed component and whether track shoe width is approved by John Deere. Factory-Installed Undercarriage Warranty does not apply to Scraper Tractors.**
3. **StructurALL Warranty** for new John Deere Products (except Compact Excavators & Loaders, Skid-Steer Loaders, Compact Track Loaders, Scraper Tractors, Pull-Type Scrapers, and Forestry Attachments, which are not eligible for **StructurALL Warranty**) begins at the date of delivery to the original retail purchaser and ends (unless terminated earlier under Section F, below) after three (3) years, or 10,000 hours (whichever occurs first). For purposes of this warranty, a product that has been rented, used for demonstration purposes for 150 or more hours, or otherwise used prior to its original retail purchase has been "used" for the total duration of such use. **StructurALL Warranty applies only to the following structural components listed below as installed on the product at the time of original manufacture. If a particular component is not listed below it is not covered by StructurALL Warranty.**

Arm; Articulation Joint (incl. pins & bushings); Bin Frame; Boom; Carbody; C-Frame*; Circle Frame; Coupler (John Deere built ONLY); Dipperstick; Draft Frame; Engine Frame; Equipment Frame; Grapple Arch and Grapple Boom; Loader Arm; Loader Frame; Mainframe; Moldboard Lift Arm; NeverGrease™ Pin Joints [Includes steering pin and bushing joints (standard equipment), roller elements (roller bearings) in bucket to boom joints and sliding elements (bushing) for boom and linkage joints (optional equipment)]; Rollover Protection Structure (ROPS); Side Frame; Swing Frame; Track Frame; Undercarriage Frame; X-Frame; Z-bar loader linkage (including bell crank and bucket driver link); Specialty booms and arms marketed as "heavy duty" by John Deere.

Items Covered by StructurALL for Cut-to-Length Forestry Machines: Front frame (welded assembly); Rear frame (welded assembly); Crane king post with basement; Middle joint frame; Cabin swing frame; Main Boom

StructurALL Warranty does not apply to:

1. Any product used primarily in extreme duty or severe duty applications such as but not limited to: demolition and wrecking, chemical plant (including fertilizer plants), salt mines, steel mill, land fill and transfer stations, scrap handling, scarifying and other applications that are similarly destructive or similarly heavy duty except specialty booms and arms as stated in Section D.3 above.
2. C-Frames on H-Series & J-Series Crawlers equipped with root rakes or used in forestry applications unless equipped with an "extreme duty" reinforcement package.
3. Cut-to-Length Forestry Heads and Slash Bundler Units.
4. Crawlers equipped with optional side booms.
5. Cut-to-Length Forestry, Excavator, and Log Loader swing bearings.
6. Motor Graders equipped with front- or rear-mounted snow wings.

E. ITEMS NOT COVERED -

John Deere is NOT responsible for the following:

1. Freight
2. Adjustments to compensate for wear, for periodic maintenance or adjustments that result from normal wear and tear.
3. Damage caused by unapproved adjustments (electronic or mechanical) to machine or machine components outside of published specifications including but not limited to engine, hydraulic components and relief valves.
4. Program updates, calibrations, and pressure adjustments.
5. Diagnostic Time
6. Additional Labor/Labour Time - Above SPG/Labor/Labour Rate
7. Additional Cleaning - Above SPG/Labor/Labour Rate
8. Rental Fees
9. Depreciation or damage caused by normal wear or application, lack of reasonable and proper maintenance, failure to follow operating instructions, misuse, negligence, collision or other accidents.
10. Premiums charged for Overtime Labor/Labour
11. Transportation to and from the dealership.
12. Travel time, mileage or service calls by the dealer.
13. Non-John Deere components or modifications, Rotobec grapples, and attachments installed aftermarket.
14. Shop supplies and maintenance items such as, but not limited to: filters, fuels, oil, hydraulic fluid, lubricants, coolants, conditioners, shop towels, cleaners and degreasers. Note: Reimbursement for refills of oils/coolants lost due to a warrantable failure is covered when a system failure occurs outside the boundaries of a normal oil change (within 25% of specified change interval as provided in the Operator's Manual).
15. Torn, cut, or worn hoses.
16. Wear items, such as, but not limited to: body liner, belts, blades, bulbs, lubricated joints (including pins and bushings), dry brakes, brake linings, dry clutch linings, saw blades, chains, skidder grapple shocks, color marking nozzles, and articulation bumpers.
17. Items such as cutting-edge parts, delimiting knives, bucket teeth and rubber track are not warranted for depreciation or damage caused by normal wear, lack of proper maintenance, misuse, failure to follow operating instructions, the elements or accident.
18. Any defect in a non-covered component, or damage to or failure of a covered component caused by a defect in a non-covered component.
19. Secondary damage which occurs from continued operation of a product after recognition of the occurrence of a failure.
20. Parts supplied or modifications done by third party suppliers.
21. Topping off fluids when fluid levels fall in the range between low and full
22. Parts/Kits not ordered on machine and installed aftermarket. These parts will be covered by any applicable parts warranty.
23. Attachments installed aftermarket – i.e. Winch not installed at factory.
24. Custom options installed outside the factory – i.e. G.R. Manufacturing option packages.
25. Used Products (except as otherwise provided in section L below).

F. TERMINATION OF WARRANTY-

John Deere is relieved of its obligations under Standard Warranty, StructurALL Warranty, Factory-Installed Undercarriage Warranty and/or Extended Warranty if:

1. Service (other than normal maintenance and replacement of service items) is performed by someone other than an authorized John Deere dealer; or
2. The product is modified or altered in ways not approved by John Deere; or
3. Any unapproved or improperly sized attachment is installed on the product. Approval and attachment size shall be at John Deere's sole discretion. (Consult dealer prior to installing attachments or product modification).
4. The product is moved outside the US and/or Canada.

G. PARTS REPLACED UNDER WARRANTY -

Only new or remanufactured parts or components furnished or approved by John Deere, will be used if John Deere elects to repair the product. If any such part or component is defective in material or workmanship when installed in the product, John Deere will repair or replace, as it elects, such defective part or component, provided the defect is

reported to an authorized John Deere dealer within 90 days of installation or before expiration of the applicable Standard Warranty, Factory-Installed Undercarriage Warranty and/or StructurALL Warranty whichever is later.

H. TELEMATICS

NOTICE: Products may be equipped with telematics hardware and software ("Telematics") that transmit data to John Deere/ Dealer. Purchaser may deactivate Telematics at www.idlink.com.

Notwithstanding Purchaser's right, title or interest in the Products, Purchaser agrees that John Deere and Dealer (their affiliates, successors and assigns), without further notice to Purchaser have the right to:

1. Access, use, collect and disclose any data generated by, collected by, or stored in, Products or any hardware or devices interfacing with Products ("Machine Data");
2. Access Machine Data directly through data reporting devices integrated within, or attached to, Products, including Telematics ("Data Reporting Systems"); and
3. Update the Data Reporting Systems software from time to time. Machine Data will only be used in accordance with John Deere's Machine Data Policy, located at www.JohnDeere.com/MachineDataPolicy.

I. OBTAINING WARRANTY SERVICE -

To obtain warranty service, the purchaser must request warranty service from a John Deere dealer authorized to sell the product to be serviced. When making such a request, the purchaser must present evidence of the product's delivery date, make the product available at the dealer's place of business, and inform the dealer in what way the purchaser believes the product to be defective. Standard Warranty, Factory-Installed Undercarriage Warranty and/or StructurALL Warranty repairs may be made in the field if the purchaser and servicing dealer so desire. However, John Deere will not be responsible for any charges (such as dealer travel time, mileage or extra labor/labour) that would not have been incurred had the product been repaired at the dealer's place of business.

J. NO IMPLIED WARRANTY, CONDITIONS OR OTHER REPRESENTATION -

Where permitted by law, neither John Deere nor any company affiliated with it makes any warranties, representations, conditions or promises, express or implied, as to the quality, performance, or freedom from defect of its products, other than those set forth in this document and **NO IMPLIED WARRANTY OF MERCHANTABILITY, CONDITIONS OR FITNESS IS MADE.**

K. NO DEALER WARRANTY -

The selling dealer makes no warranty of its own on any item covered by this warranty, and makes no warranty on other items unless the dealer delivers to the purchaser a separate written warranty certificate specifically warranting the item. **The dealer has no authority to make any representation or promise on behalf of John Deere, or to modify the terms or limitations of this warranty in any way.**

L. USED JOHN DEERE PRODUCTS ONLY -

John Deere will transfer remaining Standard Warranty, Factory-Installed Undercarriage Warranty and/or StructurALL Warranty to the purchaser of a used John Deere construction and/or forestry product that has been used for less than the full warranty period provided at the product's original retail purchase. This transfer is not effective until change of ownership is registered by a John Deere dealer. **ALL THE TERMS, INCLUDING LIMITATIONS AND EXCLUSIONS, OF THE JOHN DEERE STANDARD WARRANTY, FACTORY-INSTALLED UNDERCARRIAGE WARRANTY, AND/OR STRUCTURALL WARRANTY ORIGINALLY PROVIDED FOR THE PRODUCT REMAIN IN EFFECT AND APPLICABLE.**

644 724

P-TIER WHEEL LOADERS

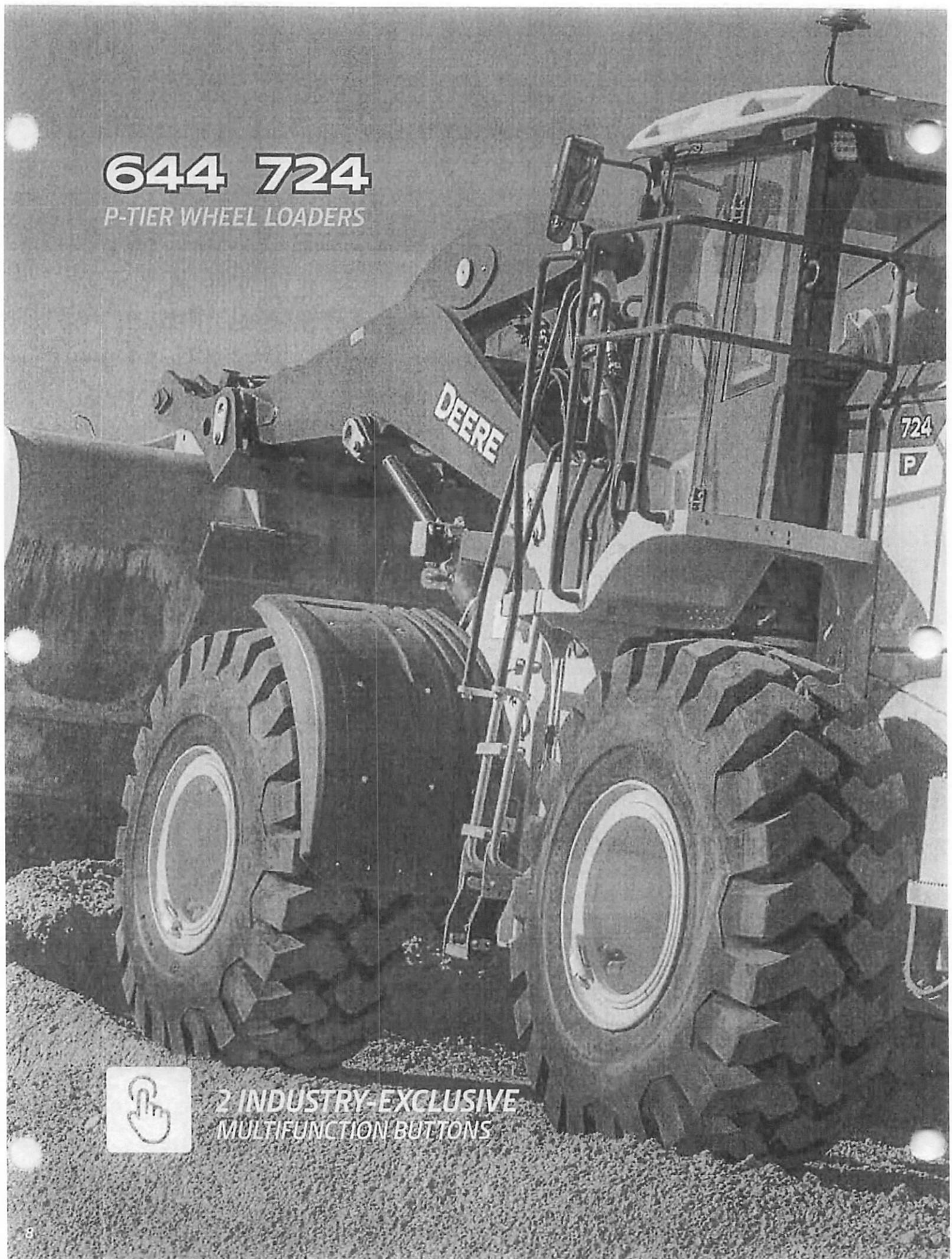

**2 INDUSTRY-EXCLUSIVE
MULTIFUNCTION BUTTONS**

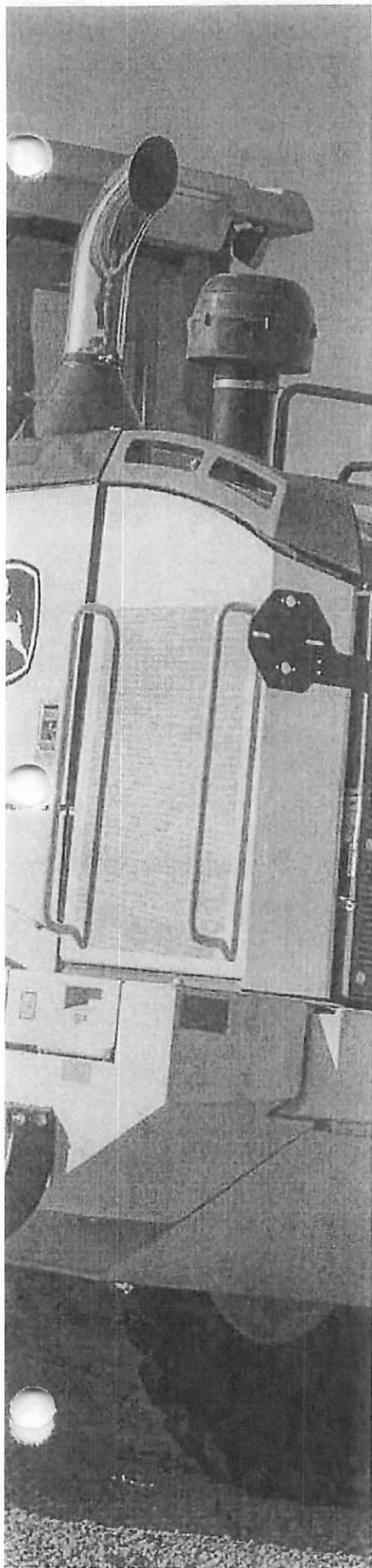

GET AHEAD

MOVING FORWARD.

Designed to elevate your productivity, the 644 and 724 P-Tier Wheel Loaders help you put your best foot forward.

Reach your potential

Three additional inches of hinge-pin height on the 724 over the 724K provides more clearance for dumping into high feeders, hoppers, trucks, and wagons.

Smooth operator

Seat-mounted right-hand joystick features two programmable multi-function buttons and electrohydraulic (EH) controls that are more intuitive to operate compared to our K-Series controls.

In the office

Roomy cab boasts three more inches of legroom than earlier models. Joystick controls, foot pedals, and sealed-switch module are all ergonomically placed for optimal comfort and convenience.



724 P-TIER WHEEL LOADER SPECIFICATIONS

While general information, pictures, and descriptions are provided, some illustrations and text may include product options and accessories NOT AVAILABLE in all regions, and in some countries products and accessories may require modifications or additions to ensure compliance with the local regulations of those countries.

Engine	724 P-TIER Z-BAR / HIGH-LIFT			
Manufacturer and Model	John Deere PowerTech™ PSS 6090		Gross Peak Torque (ISO 9249)	1325 Nm (977 lb.-ft.) at 1,300 rpm
Non-Road Emission Standard	EPA Final Tier 4/EU Stage V		Net Torque Rise	48%
Cylinders	6		Fuel System (electronically controlled)	High-pressure common rail
Valves Per Cylinder	4		Lubrication	Full-flow spin-on filter and integral cooler
Displacement	9.0 L (548 cu. in.)		Aspiration	Series turbocharged, charge air cooled
Net Peak Power (ISO 9249)	200 kW (268 hp) at 1,800 rpm		Air Cleaner	Under-hood, dual-element dry type, restriction indicator in cab monitor for service
Gross Peak Power (ISO 9249)	206 kW (276 hp) at 1,800 rpm			
Net Peak Torque (ISO 9249)	1290 Nm (951 lb.-ft.) at 1,400 rpm			
Cooling				
Fan Drive	Hydraulically driven, proportionally controlled, fan aft of coolers			
Electrical				
Electrical System	24 volt with 100-amp alternator (140-amp alternator optional)			
Batteries (2 – 12 volt)	950 CCA (each)			
Transmission System				
Type	Countershaft-type PowerShift™			
Torque Converter	Single stage, single phase			
Shift Control	Electronically modulated, adaptive, load and speed dependent			
Operator Interface	Steering-column or joystick-mounted F-N-R and gear-select lever; Quick-Shift button on hydraulic lever			
Shift Modes	Manual/auto (1st-D or 2nd-D); Quick-Shift button with 2 selectable modes: kick-down or kick-up/down; and 4 clutch cutoff settings			
	<i>Standard 5-Speed With Lockup Torque Converter</i>		<i>Optional 4-Speed</i>	
Maximum Travel Speeds (with 23.5 R 25, 1 Star L3 tires)	<i>Forward</i>	<i>Reverse</i>	<i>Forward</i>	<i>Reverse</i>
Range 1	7.1 km/h (4.4 mph)	7.5 km/h (4.7 mph)	7.2 km/h (4.5 mph)	7.6 km/h (4.7 mph)
Range 2	12.1 km/h (7.5 mph)	12.8 km/h (8.0 mph)	11.9 km/h (7.4 mph)	12.5 km/h (7.7 mph)
Range 3	20.5 km/h (12.7 mph)	26.1 km/h (16.2 mph)	22.9 km/h (14.2 mph)	23.9 km/h (14.9 mph)
Range 4	24.7 km/h (15.3 mph)	N/A	35.2 km/h (21.9 mph)	N/A
Range 5	40.0 km/h (24.9 mph)	N/A	N/A	N/A
Axles/Brakes				
Final Drives	Heavy-duty inboard-mounted planetary			
Differentials	Hydraulic locking front with conventional rear – standard; dual locking front and rear – optional			
Rear Axle Oscillation, Stop to Stop (with 23.5 R 25 tires)	26 deg. (13 deg. each direction)			
Brakes (conform to ISO 3450)				
Service	Hydraulically actuated, spring retracted, self-adjusting, inboard sun-shaft mounted, oil cooled, single disc			
Parking	Automatic spring applied, hydraulically released, driveline mounted, oil cooled, multi disc			
Tires/Wheels (see page 39 for complete tire adjustments)				
	<i>Tread Width</i>	<i>Width Over Tires</i>		
Michelin 23.5 R 25, 1 Star L-3	2170 mm (85.4 in.)	2880 mm (113.4 in.)		
Serviceability				
Refill Capacities				
Fuel Tank (with lockable cap)	351 L (92.6 gal.)	Transmission Reservoir With Vertical Filter	23 L (24.3 qt.)	
Diesel Exhaust Fluid (DEF)	18.5 L (19.5 qt.)	Axle Oil Without Coolers (front and rear, each)	22 L (23 qt.)	
Cooling System	48 L (51 qt.)	Hydraulic Reservoir and Filter	105.2 L (27.8 gal.)	
Engine Oil With Vertical Spin-On Filter	28 L (29.5 qt.)	Park Brake Oil (wet disc)	0.65 L (22 oz.)	
Hydraulic System/Steering				
Pump (loader and steering)	Variable-displacement, axial-piston pump; closed-center, pressure-compensating system			
Maximum Rated Flow at 6895 kPa (1,000 psi) and 2,250 rpm	310 L/m (82 gpm)			
System Relief Pressure (loader and steering)	27 580 kPa (4,000 psi)			
Loader Controls	2-function valve; joystick control or fingertip controls; hydraulic-function enable/disable; optional 3rd-function valve with roller or auxiliary lever and 4th-function valve with dual roller			
Steering (conforms to ISO 5010)				
Type	Power, fully hydraulic			
Articulation Angle	80-deg. arc (40 deg. each direction)			
Turning Radius (measured to centerline of outside tire)	5.64 m (18 ft. 6 in.)			

724 P-TIER WHEEL LOADER SPECIFICATIONS

724

P

While general information, pictures, and descriptions are provided, some illustrations and text may include product options and accessories NOT AVAILABLE in all regions, and in some countries products and accessories may require modifications or additions to ensure compliance with the local regulations of those countries.

Hydraulic System/Steering (continued)	724 P-TIER Z-BAR / HIGH-LIFT	
	Z-Bar	High-Lift
Hydraulic Cycle Times		
Raise	5.3 sec.	5.3 sec.
Dump	1.4 sec.	1.4 sec.
Lower (power down)	3.8 sec.	4.0 sec.
Total	10.5 sec.	10.7 sec.

Bucket Capacity Range	
Bucket Type	
Pin-On	3.2–3.8 m ³ (4.25–5.0 cu. yd.)
Coupler	3.1–3.8 m ³ (4.0–5.0 cu. yd.)

Dimensions and Specifications With Pin-On Bucket With Bolt-On Edge

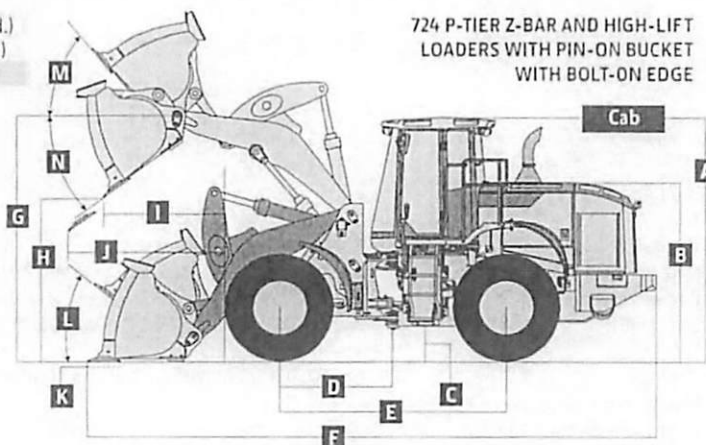

Dimensions With Bucket With Bolt-On Edge (illustration above right)	Z-Bar		High-Lift	
	3.6-m ³ (4.75 cu. yd.) general-purpose	3.8-m ³ (5.0 cu. yd.) general-purpose	3.4-m ³ (4.5 cu. yd.) general-purpose	3.6-m ³ (4.75 cu. yd.) general-purpose
A Height to Top of Cab	3.45 m (11 ft. 4 in.)	3.45 m (11 ft. 4 in.)	3.45 m (11 ft. 4 in.)	3.45 m (11 ft. 4 in.)
B Hood Height	2.51 m (8 ft. 3 in.)	2.51 m (8 ft. 3 in.)	2.51 m (8 ft. 3 in.)	2.51 m (8 ft. 3 in.)
C Ground Clearance	386 mm (15.2 in.)	386 mm (15.2 in.)	386 mm (15.2 in.)	386 mm (15.2 in.)
D Length From Centerline to Front Axle	1.66 m (5 ft. 5 in.)	1.66 m (5 ft. 5 in.)	1.66 m (5 ft. 5 in.)	1.66 m (5 ft. 5 in.)
E Wheelbase	3.31 m (10 ft. 10 in.)	3.31 m (10 ft. 10 in.)	3.31 m (10 ft. 10 in.)	3.31 m (10 ft. 10 in.)
F Overall Length, Bucket on Ground	8.42 m (27 ft. 8 in.)	8.47 m (27 ft. 9 in.)	8.77 m (28 ft. 9 in.)	8.82 m (28 ft. 11 in.)
G Height to Hinge Pin, Fully Raised	4.16 m (13 ft. 8 in.)	4.16 m (13 ft. 8 in.)	4.50 m (14 ft. 9 in.)	4.50 m (14 ft. 9 in.)
H Dump Clearance, 45 deg., Full Height	2.87 m (9 ft. 5 in.)	2.84 m (9 ft. 4 in.)	3.25 m (10 ft. 8 in.)	3.21 m (10 ft. 7 in.)
I Reach, 45-deg. Dump, Full Height	1.12 m (3 ft. 8 in.)	1.15 m (3 ft. 9 in.)	1.20 m (3 ft. 11 in.)	1.24 m (4 ft. 1 in.)
J Reach, 45-deg. Dump, 2.13-m (7 ft. 0 in.) Clearance	1.68 m (5 ft. 6 in.)	1.70 m (5 ft. 7 in.)	2.04 m (6 ft. 8 in.)	2.06 m (6 ft. 9 in.)
K Maximum Digging Depth	160 mm (6 in.)	160 mm (6 in.)	270 mm (10 in.)	270 mm (11 in.)
L Maximum Rollback at Ground Level	43 deg.	43 deg.	46 deg.	46 deg.
M Maximum Rollback, Boom Fully Raised	60 deg.	60 deg.	60 deg.	60 deg.
N Maximum Bucket Dump Angle, Fully Raised	47 deg.	47 deg.	45 deg.	45 deg.
Loader Clearance Circle, Bucket Carry Position	13.0 m (42 ft. 10 in.)	13.1 m (42 ft. 10 in.)	13.3 m (43 ft. 7 in.)	13.4 m (44 ft. 0 in.)
Specifications With Bucket With Bolt-On Edge				
Capacity, Heaped	3.6 m ³ (4.76 cu. yd.)	3.8 m ³ (5.00 cu. yd.)	3.4 m ³ (4.50 cu. yd.)	3.6 m ³ (4.76 cu. yd.)
Capacity, Struck	3.0 m ³ (3.90 cu. yd.)	3.2 m ³ (4.12 cu. yd.)	2.8 m ³ (3.68 cu. yd.)	3.0 m ³ (3.90 cu. yd.)
Bucket Weight With Bolt-On Cutting Edge	1919 kg (4,232 lb.)	1954 kg (4,308 lb.)	1880 kg (4,145 lb.)	1919 kg (4,232 lb.)
Bucket Width	3.04 m (10 ft. 0 in.)	3.04 m (10 ft. 0 in.)	3.04 m (10 ft. 0 in.)	3.04 m (10 ft. 0 in.)
Breakout Force	15 988 kg (35,248 lb.)	15 496 kg (34,163 lb.)	16 527 kg (36,436 lb.)	15,946 kg (35,155 lb.)
Tipping Load, Straight, No Tire Deflection	16 405 kg (36,167 lb.)	16 302 kg (35,940 lb.)	13 777 kg (30,373 lb.)	13 677 kg (30,153 lb.)
Tipping Load, Straight, With Tire Deflection	15 312 kg (33,757 lb.)	15 210 kg (33,532 lb.)	12 975 kg (28,605 lb.)	12 876 kg (28,387 lb.)
Tipping Load, 40-deg. Full Turn, No Tire Deflection	14 204 kg (31,315 lb.)	14 109 kg (31,106 lb.)	11 870 kg (26,168 lb.)	11 777 kg (25,964 lb.)
Tipping Load, 40-deg. Full Turn, With Tire Deflection	12 843 kg (28,314 lb.)	12 747 kg (28,102 lb.)	10 854 kg (23,929 lb.)	10 761 kg (23,724 lb.)
Rated Operating Load, 50% Full-Turn Tipping Load, No Tire Deflection (conforms to ISO 14397-1)*	7102 kg (15,657 lb.)	7055 kg (15,553 lb.)	5935 kg (13,084 lb.)	5889 kg (12,982 lb.)
Rated Operating Load, 50% Full-Turn Tipping Load, With Tire Deflection (conforms to ISO 14397-1)*	6422 kg (14,157 lb.)	6374 kg (14,051 lb.)	5427 kg (11,964 lb.)	5381 kg (11,862 lb.)
Operating Weight	19 825 kg (43,707 lb.)	19 859 kg (43,783 lb.)	19 945 kg (43,971 lb.)	19 984 kg (44,058 lb.)

Loader operating information is based on machine with identified linkage and standard equipment, PowerTech PSS 6090 (EPA Final Tier 4/EU Stage V) engine, ROPS cab, rear cast bumper/counterweight, transmission side-frame guards, bottom guards, standard tires, full fuel tank, and 79-kg (175 lb.) operator. This information is affected by changes in tires, ballast, and different attachments, and assumes no tire deflection per the standard ISO 14397-1 section 5.

*Rated operating capacity based on Deere attachments only.

724 P TIER

While general information, pictures, and descriptions are provided, some illustrations and text may include product options and accessories NOT AVAILABLE in all regions, and in some countries products and accessories may require modifications or additions to ensure compliance with the local regulations of those countries.

Dimensions and Specifications With Hi-Vis Coupler and Hook-On Bucket With Bolt-On Edge

724 P-TIER Z-BAR / HIGH-LIFT

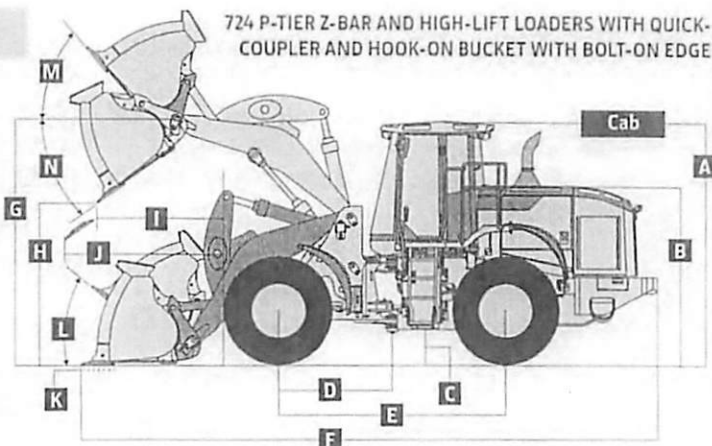

724 P-TIER Z-BAR AND HIGH-LIFT LOADERS WITH QUICK-COUPLER AND HOOK-ON BUCKET WITH BOLT-ON EDGE

Dimensions With Bucket With Bolt-On Edge (illustration above right)

	Z-Bar 3.4-m ³ (4.5 cu. yd.) general-purpose
A Height to Top of Cab	3.45 m (11 ft. 4 in.)
B Hood Height	2.51 m (8 ft. 3 in.)
C Ground Clearance	386 mm (15.2 in.)
D Length From Centerline to Front Axle	1.66 m (5 ft. 5 in.)
E Wheelbase	3.31 m (10 ft. 10 in.)
F Overall Length, Bucket on Ground	8.46 m (27 ft. 9 in.)
G Height to Hinge Pin, Fully Raised	4.16 m (13 ft. 8 in.)
H Dump Clearance, 45 deg., Full Height	2.85 m (9 ft. 4 in.)
I Reach, 45-deg. Dump, Full Height	1.15 m (3 ft. 9 in.)
J Reach, 45-deg. Dump, 2.13-m (7 ft. 0 in.) Clearance	1.70 m (5 ft. 7 in.)
K Maximum Digging Depth	150 mm (6 in.)
L Maximum Rollback at Ground Level	43 deg.
M Maximum Rollback, Boom Fully Raised	60 deg.
N Maximum Bucket Dump Angle, Fully Raised	47 deg.
Loader Clearance Circle, Bucket Carry Position	13.1 m (42 ft. 10 in.)

Specifications With Bucket With Bolt-On Edge

	Z-Bar 3.4-m ³ (4.5 cu. yd.) general-purpose
Capacity, Heaped	3.5 m ³ (4.51 cu. yd.)
Capacity, Struck	2.8 m ³ (3.70 cu. yd.)
Bucket Weight With Bolt-On Cutting Edge	1737 kg (3,829 lb.)
Bucket Width	3.04 m (10 ft. 0 in.)
Breakout Force	15 478 kg (34,123 lb.)
Tipping Load, Straight, No Tire Deflection	15 644 kg (34,489 lb.)
Tipping Load, Straight, With Tire Deflection	14 589 kg (32,163 lb.)
Tipping Load, 40-deg. Full Turn, No Tire Deflection	13 493 kg (29,746 lb.)
Tipping Load, 40-deg. Full Turn, With Tire Deflection	12 177 kg (26,846 lb.)
Rated Operating Load, 50% Full-Turn Tipping Load, No Tire Deflection (conforms to ISO 14397-1)*	6746 kg (14,873 lb.)
Rated Operating Load, 50% Full-Turn Tipping Load, With Tire Deflection (conforms to ISO 14397-1)*	6089 kg (13,423 lb.)
Operating Weight	20 299 kg (44,753 lb.)

Loader operating information is based on machine with identified linkage and standard equipment, PowerTech PSS 6090 (EPA Final Tier 4/EU Stage V) engine, ROPS cab, rear cast bumper/counterweight, transmission side-frame guards, bottom guards, standard tires, full fuel tank, and 79-kg (175 lb.) operator. This information is affected by changes in tires, ballast, and different attachments, and assumes no tire deflection per the standard ISO 14397-1 section 5.

*Rated operating capacity based on Deere attachments only.

Dimensions and Specifications With Hi-Vis Coupler and Construction Forks

	Z-Bar 1.52-m (60 in.) tine length
A Height to Top of Cab	3.45 m (11 ft. 4 in.)
B Hood Height	2.51 m (8 ft. 3 in.)
C Ground Clearance	386 mm (15.2 in.)
D Length From Centerline to Front Axle	1.66 m (5 ft. 5 in.)
E Wheelbase	3.31 m (10 ft. 10 in.)
F Overall Length, Forks on Ground	9.00 m (29 ft. 6 in.)
G Height to Hinge Pin, Fully Raised	4.16 m (13 ft. 8 in.)
H Reach, Fully Raised	810 mm (32 in.)
I Fork Height, Fully Raised	3.85 m (12 ft. 7 in.)
J Maximum Reach, Fork Level	1.72 m (5 ft. 8 in.)
K Fork Height, Maximum Reach	1.74 m (5 ft. 9 in.)
L Reach, Ground Level	1.15 m (3 ft. 9 in.)
M Depth Below Ground	110 mm (4 in.)
N Tine Length	1.52 m (60 in.)
O Load Position, 50% Tine Length	760 mm (30 in.)

	Z-Bar 3.6-m ³ (4.75 cu. yd.) general-purpose
A Height to Top of Cab	3.45 m (11 ft. 4 in.)
B Hood Height	2.51 m (8 ft. 3 in.)
C Ground Clearance	386 mm (15.2 in.)
D Length From Centerline to Front Axle	1.66 m (5 ft. 5 in.)
E Wheelbase	3.31 m (10 ft. 10 in.)
F Overall Length, Bucket on Ground	8.51 m (27 ft. 11 in.)
G Height to Hinge Pin, Fully Raised	4.16 m (13 ft. 8 in.)
H Dump Clearance, 45 deg., Full Height	2.81 m (9 ft. 3 in.)
I Reach, 45-deg. Dump, Full Height	1.18 m (3 ft. 10 in.)
J Reach, 45-deg. Dump, 2.13-m (7 ft. 0 in.) Clearance	1.71 m (5 ft. 7 in.)
K Maximum Digging Depth	160 mm (6 in.)
L Maximum Rollback at Ground Level	43 deg.
M Maximum Rollback, Boom Fully Raised	60 deg.
N Maximum Bucket Dump Angle, Fully Raised	47 deg.
Loader Clearance Circle, Bucket Carry Position	13.1 m (42 ft. 11 in.)

	Z-Bar 3.6-m ³ (4.75 cu. yd.) general-purpose
Capacity, Heaped	3.6 m ³ (4.76 cu. yd.)
Capacity, Struck	3.0 m ³ (3.91 cu. yd.)
Bucket Weight With Bolt-On Cutting Edge	1774 kg (3,911 lb.)
Bucket Width	3.04 m (10 ft. 0 in.)
Breakout Force	14 977 kg (33,018 lb.)
Tipping Load, Straight, No Tire Deflection	15 537 kg (34,254 lb.)
Tipping Load, Straight, With Tire Deflection	14 484 kg (31,932 lb.)
Tipping Load, 40-deg. Full Turn, No Tire Deflection	13 395 kg (29,530 lb.)
Tipping Load, 40-deg. Full Turn, With Tire Deflection	12 081 kg (26,634 lb.)
Rated Operating Load, 50% Full-Turn Tipping Load, No Tire Deflection (conforms to ISO 14397-1)*	6697 kg (14,765 lb.)
Rated Operating Load, 50% Full-Turn Tipping Load, With Tire Deflection (conforms to ISO 14397-1)*	6041 kg (13,317 lb.)
Operating Weight	20 335 kg (44,830 lb.)

	High-Lift 3.2-m ³ (4.25 cu. yd.) general-purpose
A Height to Top of Cab	3.45 m (11 ft. 4 in.)
B Hood Height	2.51 m (8 ft. 3 in.)
C Ground Clearance	386 mm (15.2 in.)
D Length From Centerline to Front Axle	1.66 m (5 ft. 5 in.)
E Wheelbase	3.31 m (10 ft. 10 in.)
F Overall Length, Bucket on Ground	8.82 m (28 ft. 11 in.)
G Height to Hinge Pin, Fully Raised	4.50 m (14 ft. 9 in.)
H Dump Clearance, 45 deg., Full Height	3.22 m (10 ft. 7 in.)
I Reach, 45-deg. Dump, Full Height	1.24 m (4 ft. 1 in.)
J Reach, 45-deg. Dump, 2.13-m (7 ft. 0 in.) Clearance	2.06 m (6 ft. 9 in.)
K Maximum Digging Depth	270 mm (10 in.)
L Maximum Rollback at Ground Level	45 deg.
M Maximum Rollback, Boom Fully Raised	60 deg.
N Maximum Bucket Dump Angle, Fully Raised	45 deg.
Loader Clearance Circle, Bucket Carry Position	13.5 m (44 ft. 4 in.)

	High-Lift 3.2-m ³ (4.25 cu. yd.) general-purpose
Capacity, Heaped	3.3 m ³ (4.26 cu. yd.)
Capacity, Struck	2.7 m ³ (3.48 cu. yd.)
Bucket Weight With Bolt-On Cutting Edge	1695 kg (3,737 lb.)
Bucket Width	3.04 m (10 ft. 0 in.)
Breakout Force	15 900 kg (35,053 lb.)
Tipping Load, Straight, No Tire Deflection	13 089 kg (28,855 lb.)
Tipping Load, Straight, With Tire Deflection	12 312 kg (27,143 lb.)
Tipping Load, 40-deg. Full Turn, No Tire Deflection	11 221 kg (24,738 lb.)
Tipping Load, 40-deg. Full Turn, With Tire Deflection	10 236 kg (22,566 lb.)
Rated Operating Load, 50% Full-Turn Tipping Load, No Tire Deflection (conforms to ISO 14397-1)*	5610 kg (12,369 lb.)
Rated Operating Load, 50% Full-Turn Tipping Load, With Tire Deflection (conforms to ISO 14397-1)*	5118 kg (11,283 lb.)
Operating Weight	20 417 kg (45,012 lb.)

Loader operating information is based on machine with identified linkage and standard equipment, PowerTech PSS 6090 (EPA Final Tier 4/EU Stage V) engine, ROPS cab, rear cast bumper/counterweight, transmission side-frame guards, bottom guards, standard tires, full fuel tank, and 79-kg (175 lb.) operator. This information is affected by changes in tires, ballast, and different attachments, and assumes no tire deflection per the standard ISO 14397-1 section 5.

*Rated operating capacity based on Deere attachments only.

	High-Lift 3.4-m ³ (4.5 cu. yd.) general-purpose
A Height to Top of Cab	3.45 m (11 ft. 4 in.)
B Hood Height	2.51 m (8 ft. 3 in.)
C Ground Clearance	386 mm (15.2 in.)
D Length From Centerline to Front Axle	1.66 m (5 ft. 5 in.)
E Wheelbase	3.31 m (10 ft. 10 in.)
F Overall Length, Bucket on Ground	8.86 m (29 ft. 1 in.)
G Height to Hinge Pin, Fully Raised	4.50 m (14 ft. 9 in.)
H Dump Clearance, 45 deg., Full Height	3.19 m (10 ft. 6 in.)
I Reach, 45-deg. Dump, Full Height	1.27 m (4 ft. 2 in.)
J Reach, 45-deg. Dump, 2.13-m (7 ft. 0 in.) Clearance	2.08 m (6 ft. 10 in.)
K Maximum Digging Depth	270 mm (11 in.)
L Maximum Rollback at Ground Level	45 deg.
M Maximum Rollback, Boom Fully Raised	60 deg.
N Maximum Bucket Dump Angle, Fully Raised	45 deg.
Loader Clearance Circle, Bucket Carry Position	13.5 m (44 ft. 4 in.)

	High-Lift 3.4-m ³ (4.5 cu. yd.) general-purpose
Capacity, Heaped	3.5 m ³ (4.51 cu. yd.)
Capacity, Struck	2.8 m ³ (3.70 cu. yd.)
Bucket Weight With Bolt-On Cutting Edge	1737 kg (3,829 lb.)
Bucket Width	3.04 m (10 ft. 0 in.)
Breakout Force	15 437 kg (34,032 lb.)
Tipping Load, Straight, No Tire Deflection	13 009 kg (28,679 lb.)
Tipping Load, Straight, With Tire Deflection	12 231 kg (26,965 lb.)
Tipping Load, 40-deg. Full Turn, No Tire Deflection	11 146 kg (24,572 lb.)
Tipping Load, 40-deg. Full Turn, With Tire Deflection	10 158 kg (22,395 lb.)
Rated Operating Load, 50% Full-Turn Tipping Load, No Tire Deflection (conforms to ISO 14397-1)*	5573 kg (12,286 lb.)
Rated Operating Load, 50% Full-Turn Tipping Load, With Tire Deflection (conforms to ISO 14397-1)*	5079 kg (11,197 lb.)
Operating Weight	20 459 kg (45,103 lb.)

Loader operating information is based on machine with identified linkage and standard equipment, PowerTech PSS 6090 (EPA Final Tier 4/EU Stage V) engine, ROPS cab, rear cast bumper/counterweight, transmission side-frame guards, bottom guards, standard tires, full fuel tank, and 79-kg (175 lb.) operator. This information is affected by changes in tires, ballast, and different attachments, and assumes no tire deflection per the standard ISO 14397-1 section 5.

*Rated operating capacity based on Deere attachments only.

While general information, pictures, and descriptions are provided, some illustrations and text may include product options and accessories NOT AVAILABLE in all regions, and in some countries products and accessories may require modifications or additions to ensure compliance with the local regulations of those countries.

Dimensions and Specifications With Hi-Vis Coupler and Construction Forks (continued)

724 P-TIER Z-BAR / HIGH-LIFT

724 P-TIER Z-BAR AND HIGH-LIFT LOADERS WITH QUICK-COUPLER AND HOOK-ON CONSTRUCTION FORKS

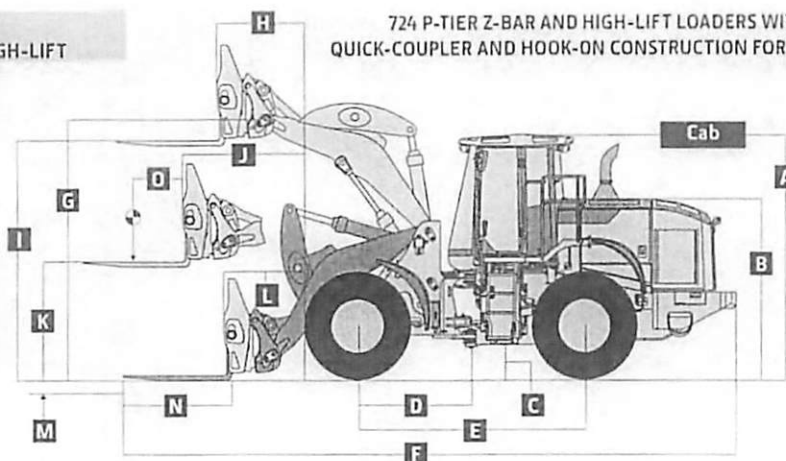

Specifications With Forks (illustration above right)

	Z-Bar	Z-Bar	High-Lift	High-Lift
Tipping Load, Straight, No Tire Deflection	10 998 kg (24,247 lb.)	10 441 kg (23,018 lb.)	9653 kg (21,280 lb.)	9194 kg (20,270 lb.)
Tipping Load, Straight, With Tire Deflection	10 668 kg (23,519 lb.)	10 137 kg (22,348 lb.)	9372 kg (20,662 lb.)	8931 kg (19,689 lb.)
Tipping Load, 40-deg. Full Turn, No Tire Deflection	9528 kg (21,006 lb.)	9036 kg (19,921 lb.)	8320 kg (18,342 lb.)	7915 kg (17,450 lb.)
Tipping Load, 40-deg. Full Turn, With Tire Deflection	9090 kg (20,040 lb.)	8631 kg (19,028 lb.)	7950 kg (17,527 lb.)	7569 kg (16,687 lb.)
Rated Operating Load, 50% Full-Turn Tipping Load, With Tire Deflection (conforms to ISO 14397-1 and SAE J1197)*	4545 kg (10,020 lb.)	4316 kg (9,514 lb.)	3975 kg (8,763 lb.)	3785 kg (8,343 lb.)
Rated Operating Load, Rough Terrain, 60% Full-Turn Tipping Load, With Tire Deflection (conforms to EN474-3)*	5454 kg (12,024 lb.)	5179 kg (11,417 lb.)	4770 kg (10,516 lb.)	4541 kg (10,012 lb.)
Rated Operating Load, Firm and Level Ground, 80% Full-Turn Tipping Load, With Tire Deflection (conforms to EN474-3)*	7272 kg (16,032 lb.)	6905 kg (15,222 lb.)	6360 kg (14,021 lb.)	6055 kg (13,349 lb.)
Operating Weight	19 670 kg (43,366 lb.)	19 731 kg (43,499 lb.)	19 830 kg (43,717 lb.)	19 890 kg (43,849 lb.)

Loader operating information is based on machine with identified linkage and standard equipment, PowerTech PSS 6090 (EPA Final Tier 4/EU Stage V) engine, ROPS cab, rear cast bumper/counterweight, transmission side-frame guards, bottom guards, standard tires, full fuel tank, and 79-kg (175 lb.) operator. This information is affected by changes in tires, ballast, and different attachments, and assumes no tire deflection per the standard ISO 14397-1 section 5.

*Rated operating capacity based on Deere attachments only.

Adjustments to Operating Weights and Tipping Loads With Buckets

Adjustments to operating weights, tipping loads, and tires are based on Z-Bar machine with pin-on 3.6-m³ (4.75 cu. yd.) general-purpose bucket with bolt-on cutting edge, ROPS cab, rear cast bumper/counterweight, transmission side-frame guards, bottom guards, standard tires, full fuel tank, and 79-kg (175 lb.) operator*

Add (+) or deduct (-) kg (lb.) as indicated

for loaders with 3-piece rims

Michelin 23.5 R 25, 1 Star L-3

Bridgestone 23.5 R 25, 1 Star L-3

Titan 23.5-25, 20 PR L-3

Titan 725/70-25, 16-Ply L-4T (Logger Style)¹⁵

Michelin 750/65 R 25, 1 Star L-3T¹⁶

Operating Weight	Tipping Load, Straight	Tipping Load, 40-deg. Full Turn	Tread Width	Width Over Tires	Vertical Height
0 kg (0 lb.)	0 kg (0 lb.)	0 kg (0 lb.)	0 mm (0 in.)	0 mm (0 in.)	0 mm (0 in.)
+101 kg (+223 lb.)	+77 kg (+170 lb.)	+68 kg (+150 lb.)	-3 mm (-0.1 in.)	+15 mm (+0.6 in.)	+39 mm (+1.5 in.)
-271 kg (-597 lb.)	-206 kg (-455 lb.)	-182 kg (-401 lb.)	-3 mm (-0.1 in.)	+33 mm (+1.3 in.)	+29 mm (+1.1 in.)
+359 kg (+792 lb.)	+284 kg (+627 lb.)	+251 kg (+554 lb.)	+31 mm (+1.2 in.)	+116 mm (+4.6 in.)	+78 mm (+3.1 in.)
+715 kg (+1,577 lb.)	+556 kg (+1,225 lb.)	+491 kg (+1,081 lb.)	+31 mm (+1.2 in.)	+137 mm (+5.4 in.)	+42 mm (+1.7 in.)

*May change based on vehicle configuration, weight, or tire-pressure adjustments.

¹⁵Equipped with 5-piece heavy-duty rims.

¹⁶CaCl₂ not recommended.

¹⁷Requires 9-deg. rear axle stops.

Bucket Selection Guides

LOOSE MATERIALS	kg/m ³	lb./cu. yd.	LOOSE MATERIALS	kg/m ³	lb./cu. yd.
Chips, pulverized	288	586	Limestone, coarse, sized	1570	2,046
Clay (ball, white, clinker)	873	1,814	Limestone, medium sized	1682	2,235
Clay and gravel, dry	1602	2,800	Limestone, pulverized or crushed	1362	2,295
Clay, compact, solid	1746	2,943	Sand, damp	2083	3,510
Clay, dry in lump base	1029	1,701	Sand, dry	1762	2,970
Clay, maturated in water	1282	2,160	Sand, voids, full of water	2083	3,510
Coal, anthracite, broken, home	865	1,458	Sandstone, quarried	1314	2,214
Coal, bituminous, moderately wet	821	1,350	Slake, broken, crushed	1362	2,295
Earth, common loam, dry	1218	2,052	Slag, furnace granulated	1955	3,294
Earth, mud, packed	1843	3,105	Stone or gravel, 37.5 to 47.5 mm		
Granite, broken	1538	2,592	(1.5 to 3.5" size)	1442	2,430
Gypsum	2275	3,834	Stone or gravel, 18.75 mm (0.75" size)	1602	2,700

Bucket Fill Factors

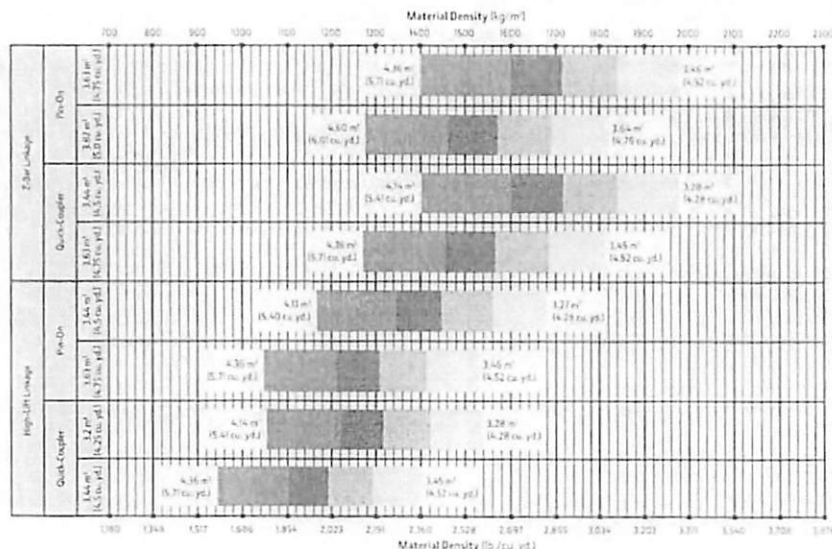
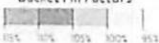

Additional equipment

Key: ● Standard ▲ Optional or special See your John Deere dealer for further information.

444 P	524 P	544 P	624 P	644 P	724 P	Engine	444 P	524 P	544 P	624 P	644 P	724 P	Quad-Cool™ Cooling System
●	●	●	●	●	●	Wet-sleeve cylinder liners	●	●	●	●	●	●	Heavy-duty, trash-resistant radiator and high-ambient cooling package
●	●	●	●	●	●	Programmable auto-idle and auto shutdown	●	●	●	●	●	●	2-side access to all coolers
●	●	●	●	●	●	Selected idle adjustment from 900–1,250 rpm	●	●	●	●	●	●	Isolated from engine compartment
●	●	●	●	●	●	Starter excessive-cranking protection	●	●	●	●	●	●	Engine radiator
●	●	●	●	●	●	Automatic engine cool-down timer	●	●	●	●	●	●	Engine oil cooler
●	●	●	●	●	●	Automatic derating for exceeded system temperatures	●	●	●	●	●	●	Hydraulic oil cooler (oil to air)
●	●	●	●	●	●	Serpentine drive belt for automatic tensioner	●	●	●	●	●	●	Transmission oil cooler (oil to air)
●	●	●	●	●	●	Electrical fuel-priming pump	●	●	●	●	●	●	Charge air cooler (air to air)
●	●	●	●	●	●	Dual-stage fuel filter and water separator	●	●	●	●	●	●	Fuel cooler
●	●	●	●	●	●	500-hour vertical spin-on oil filter	●	●	●	●	●	●	Coolant recovery tank
▲	▲	▲	▲	▲	▲	Engine-compartment light	●	●	●	●	●	●	Antifreeze, –37 deg. C (–34 deg. F)
▲	▲	▲	▲	▲	▲	Chrome exhaust stack	●	●	●	●	●	●	Cool-on-demand, hydraulically driven, swing-out fan
●	●	●	●	●	●	Automatic glow plugs for cold start	●	●	●	●	●	●	Enclosed fan safety guard
					▲	Automatic ether starting aid (recommended for cold starts below –12 deg. C [10 deg. F])	▲	▲	▲	▲	▲	▲	Automatic reversing fan drive
▲	▲	▲	▲	▲	▲	Engine-block heater (recommended for cold starts below –23 deg. C [–10 deg. F])	▲	▲	▲	▲	▲	▲	Axle and service-brake coolers
▲	▲	▲	▲	▲	▲	Centrifugal engine air pre-cleaner	▲	▲	▲	▲	▲	▲	Hydraulics
▲	▲	▲	▲	▲	▲	Throttle lock	●	●	●	●	●	●	Electrohydraulic (EH) controls with soft stops and adjustable settings
						Powertrain	●	●	●	●	●	●	In-cab adjustable automatic return-to-dig bucket positioner
●	●	●	●	●	●	Clutch cutoff with 4 operator settings: Automatic, level ground, small slope, or steep slope	●	●	●	●	●	●	In-cab adjustable automatic boom-height kickout/return to carry
●	●	●	●	●	●	Programmable maximum high gear	●	●	●	●	●	●	Reservoir with sight gauge and fill strainer
●	●	●	●	●	●	Clutch calibration engaged from monitor	●	●	●	●	●	●	Hydraulic diagnostic ports
●	●	●	●	●	●	2,000-hour vertical spin-on transmission filter	▲	▲	▲	▲	▲	▲	4,000-hour in-tank filter
●	●	●	●	●	●	Transmission fill tube and sight gauge	▲	▲	▲	▲	▲	▲	2 function — joystick with F-N-R
●	●	●	●	●	●	Transmission diagnostic ports	▲	▲	▲	▲	▲	▲	2 function — 2-lever fingertip controls and steering column F-N-R
●					▲	4-speed transmission with non-lockup torque converter	▲	▲	▲	▲	▲	▲	3 function — joystick with F-N-R and integrated 3rd-function roller
	●	▲	▲			5-speed transmission with non-lockup torque converter	▲	▲	▲	▲	▲	▲	3 function — 3-lever fingertip controls and steering column F-N-R
		●	●	●	●	5-speed transmission with lockup torque converter	●	●	●	●	●	●	4 function — joystick with F-N-R and integrated 3rd/4th-function rollers
●	●	●	●	●	●	Front locking differential	●	●	●	●	●	●	Programmable multifunction buttons (2)
▲	▲	▲	▲	▲	▲	Rear locking differential	●	●	●	●	●	●	Adjustable and continuous hydraulic-flow settings
●	●	●	●	●	●	Brake retractors and adjusters	▲	▲	▲	▲	▲	▲	Programmable attachment settings
▲	▲	▲	▲	▲	▲	Automatic differential lock	▲	▲	▲	▲	▲	▲	Ride control, automatic with monitor-adjustable speed settings
●	●	●	●	●	●	Axle oil temperature sensing	▲	▲	▲	▲	▲	▲	Hydraulic control system for quick-coupler locking pins
▲	▲	▲	▲	▲	▲	Wheel-spin control	▲	▲	▲	▲	▲	▲	Hydra™ XR cold-temperature hydraulic fluid recommended below –25 deg. C (–13 deg. F)

While general information, pictures, and descriptions are provided, some illustrations and text may include product options and accessories NOT AVAILABLE in all regions, and in some countries products and accessories may require modifications or additions to ensure compliance with the local regulations of those countries.

Net engine power is with standard equipment including air cleaner, exhaust system, alternator, and cooling fan at test conditions per ISO 9249. No derating is required up to 3050-m (10,000 ft.) altitude. Specifications and design subject to change without notice. Specifications with the exception of bucket capacity are in accordance with all applicable ISO standards. Except where otherwise noted, these specifications are based on units with applicable linkage and standard equipment, ROPS cab, rear cast bumper/counter weight, transmission side-frame guards, bottom guards, standard tires, full fuel tank, and 79-kg (175 lb) operator.

Additional equipment (cont.)

Key: ● Standard ▲ Optional or special See your John Deere dealer for further information.

444 P	524 P	544 P	624 P	644 P	724 P	Steering Systems
●	●	●	●	●	●	Conventional steering wheel with spinner knob
					▲	Joystick steering (including conventional steering column) with gearshift, F-N-R, and horn
▲	▲	▲	▲	▲	▲	Secondary steering
Electrical						
●	●	●	●	●	●	Solid-state electrical power-distribution system
●	●	●	●	●	●	Lockable master electrical-disconnect switch
●	●	●	●	●	●	Battery-terminal safety covers
●	●	●	●	●	●	By-pass start safety cover at starter
●	●	●	●	●	●	Remote jump-start access in battery box
●	●	●	●	●	●	Pre-wired for beacon/strobe light
●	●	●	●	●	●	Lights: Halogen driving lights with guards (2) / Front (4), rear cab (2), and rear grille (2) work lights / LED front turn signals and flashers / LED stop- and taillights
▲	▲	▲	▲	▲	▲	Premium LED light package (all exterior lights are heavy-duty LED)
●	●	●	●	●	●	Programmable courtesy lights
●	●	●	●	●	●	Horn, electric
●	●	●	●	●	●	Reverse warning alarm
▲	▲	▲	▲	▲	▲	Multifunction/multi-language 178-mm (7 in.) LCD color monitor includes: Digital instruments — Analog display (hydraulic oil temperature, engine coolant temperature, transmission oil temperature, and engine oil pressure) / Digital display (engine rpm, transmission gear/direction indicator, hour meter, fuel level, diesel exhaust fluid (DEF) level, speedometer, odometer, and average fuel consumption)
▲	▲	▲	▲	▲	▲	Multifunction/multi-language 127-mm (5 in.) LCD color monitor includes: Digital instruments — Analog display (hydraulic oil temperature, engine coolant temperature, transmission oil temperature, and engine oil pressure) / Digital display (engine rpm, transmission gear/direction indicator, hour meter, fuel level, DEF level, speedometer, odometer, and average fuel consumption)
▲	▲	▲	▲	●	●	Integrated cycle counter with 5 categories
●	●	●	●	●	●	Indicator lights: Standard and selected options / Amber caution and red stop

444 P	524 P	544 P	624 P	644 P	724 P	Electrical (continued)
●	●	●	●	●	●	Operator-warning messages
●	●	●	●	●	●	Built-in diagnostics: Diagnostic-code details / Sensor values / Calibrations / Individual circuit tester
▲	▲	▲	▲	▲	▲	Electrical corrosion-prevention package
●	●	●	●	●	●	Standard AM/FM/Weather-Band (WB) radio with remote auxiliary port
▲	▲	▲	▲	▲	▲	Premium AM/FM/WB radio with Bluetooth®, remote auxiliary port, and remote USB port (premium cab only)
●	●	●	●	●	●	24- to 12-volt, 8-amp converter and cab power ports (3)
▲	▲	▲	▲	▲	▲	24- to 12-volt, 15- or 30-amp converter and cab power ports (3)
Operator's Station						
●	●	●	●	●	●	Standard cab with air conditioning/heater (ROPS/FOPS Level 1, isolation mounted)
▲	▲	▲	▲	▲	▲	Premium cab with air conditioning/heater (ROPS/FOPS Level 1, isolation mounted)
▲	▲	▲	▲	▲	▲	Automatic temperature control (premium cab only)
●	●	●	●	●	●	Rear window defrost vent
●	●	●	●	●	●	Keyless start with multiple security modes
●	●	●	●	●	●	Sealed-switch module with function indicators
●	●	●	●	●	●	Seat with backrest extension, deep foam, fabric cover, and adjustable air suspension
▲	▲	▲	▲	▲	▲	Premium seat with high-wide back- and headrest extension, heated and ventilated, leather/fabric cover, and adjustable heavy-duty air suspension
●	●	●	●	●	●	Hydraulic controls integrated to seat
●	●	●	●	●	●	High-visibility, bright-orange seat belt, 76 mm (3 in.), with retractor
▲	▲	▲	▲	▲	▲	Seat-belt minder monitoring with JDLink™ and seat-belt indicator beacon
●	●	●	●	●	●	Cup holder and cup/Thermos® holder with retaining strap
●	●	●	●	●	●	Lunch-box/cooler holder with tie-down brackets
●	●	●	●	●	●	Coat hook
●	●	●	●	●	●	LED dome and reading light
●	●	●	●	●	●	Rubber floor mat
●	●	●	●	●	●	Dual-tilt steering column
●	●	●	●	●	●	Operator's manual storage compartment

Operator's Station continued on next page

While general information, pictures, and descriptions are provided, some illustrations and text may include product options and accessories NOT AVAILABLE in all regions, and in some countries products and accessories may require modifications or additions to ensure compliance with the local regulations of those countries.

Net engine power is with standard equipment including air cleaner, exhaust system, alternator, and cooling fan at test conditions per ISO 9249. No derating is required up to 3050-m (10,000 ft.) altitude. Specifications and design subject to change without notice. Specifications with the exception of bucket capacity are in accordance with all applicable ISO standards. Except where otherwise noted, these specifications are based on units with applicable linkage and standard equipment, ROPS cab, rear cast bumper/counterweight, transmission side-frame guards, bottom guards, standard tires, full fuel tank, and 79-kg (175 lb.) operator.

Additional equipment (cont.)

Key: ● Standard ▲ Optional or special See your John Deere dealer for further information.

444 P 524 P 544 P 624 P 644 P 724 P Operator's Station (continued)

444 P	524 P	544 P	624 P	644 P	724 P	Operator's Station (continued)
●	●	●	●	●	●	Outside (2) and inside (1) rearview mirrors
▲	▲	▲	▲	▲	▲	Heated outside mirrors with convex lens
▲	▲	▲	▲	▲	▲	In-cab adjustable heated outside mirrors with convex lens (premium cab only)
●	●	●	●	●	●	Left-side operator-station access
●	●	●	●	●	●	Slip-resistant steps and ergonomic handholds
●	●	●	●	●	●	Pull-down front sun visor
●	●	●	●	●	●	Front and rear intermittent windshield wipers and washers
▲	▲	▲	▲	▲	▲	Powered cab air pre-cleaner
▲	▲	▲	▲	▲	▲	Beacon bracket only
▲	▲	▲	▲	▲	▲	Beacon bracket with strobe beacon
●	●	●	●	●	●	Rearview camera
▲	▲	▲	▲	▲	▲	Rearview camera with radar object-detection system
▲	▲	▲	▲	▲	▲	Dedicated 178-mm (7 in.) rear camera display
●	●	●	●	●	●	Payload scale ready
▲	▲	▲	▲	▲	▲	Fire extinguisher
Loader Linkage						
●	●	●	●	●	●	Z-Bar loader linkage (parallel lift)
▲	▲	▲	▲	▲	▲	High-Lift Z-Bar loader linkage (parallel lift)
	▲	▲	▲			High-Lift Plus Z-Bar loader linkage (parallel lift)
	▲		▲			Tool Carrier linkage for visibility (parallel lift)
Buckets and Attachments						
▲	▲	▲	▲	▲	▲	Full line of Deere pin-on buckets, coupler buckets, and forks
▲	▲	▲	▲	▲	▲	John Deere hydraulic coupler that accepts JRB-pattern attachments
▲	▲	▲	▲	▲	▲	Hi-Vis hydraulic coupler that accepts Euro-pattern attachments (ISO)
Overall Vehicle						
●	●	●	●	●	●	JDLINK wireless communication system (available in specific countries; see your dealer for details)
●	●	●	●	●	●	NeverGrease™ rear-axle oscillation
●	●	●	●	●	●	Front and rear tie-downs
●	●	●	●	●	●	Rear cast bumper/counterweight with rear hitch and locking pin

444 P 524 P 544 P 624 P 644 P 724 P Overall Vehicle (continued)

444 P	524 P	544 P	624 P	644 P	724 P	Overall Vehicle (continued)
●	●	●	●	●	●	Articulation locking bar
●	●	●	●	●	●	Loader boom service locking bar
●	●	●	●	●	●	40-deg. steering articulation to each side with rubber-cushion stops on frame
●	●	●	●	●	●	Vandal protection with lockable engine enclosures, right counterweight storage, and filler access for radiator/fuel/DEF/hydraulic transmission
●	●	●	●	●	●	Left-side service steps and handholds
▲	▲	▲	▲	▲	▲	Right-side service steps and handrails
●	●	●	●	●	●	Left-side close-mounted steps
●	●	●	●	●	●	Storage compartment
●	●	●	●	●	●	Fuel-tank fill strainer
●	●	●	●	●	●	Heavy-duty fuel-tank guard
●	●	●	●	●	●	Ground-level fuel and DEF fill
●	●	●	●	●	●	Same-side ground-level daily servicing
▲	●	●	●			17.5R25 tires on 3-piece rims
						20.5R25 tires on 3-piece rims
					●	23.5R25 tires on 3-piece rims
					▲	23.5R25 tires on 5-piece rims
					▲	Tire-pressure monitoring system
					▲	Ag material-handling package
					▲	Waste handler (Z-Bar and High-Lift)
					●	Environmental drains and sample ports for engine, transmission, hydraulic oils, and engine coolant
					▲	Quick fluid service (engine, transmission, hydraulic oils, and engine coolant)
					▲	Fast-fuel system
●	●	●	●	●	●	Fenders, front narrow
▲	▲	▲	▲	▲	▲	Fenders, front full width
▲	▲	▲	▲	▲	▲	Fenders, front and rear full width
▲	▲	▲	▲	▲	▲	Fenders, front and rear full width with mud flaps
▲	▲	▲	▲	▲	▲	Less wheels and tires with axle stops
▲	▲	▲	▲	▲	▲	Rims less tires
▲	▲	▲	▲	▲	▲	Transmission side-frame and bottom guards
					▲	Special guarding for waste applications
					▲	Lift eyes
					▲	License-plate bracket and light

While general information, pictures, and descriptions are provided, some illustrations and text may include product options and accessories NOT AVAILABLE in all regions, and in some countries products and accessories may require modifications or additions to ensure compliance with the local regulations of those countries.

Net engine power is with standard equipment including air cleaner, exhaust system, alternator, and cooling fan at test conditions per ISO 9249. No derating is required up to 3050-m (10,000 ft.) altitude. Specifications and design subject to change without notice. Specifications with the exception of bucket capacity are in accordance with all applicable ISO standards. Except where otherwise noted, these specifications are based on units with applicable linkage and standard equipment, ROPS cab, rear cast bumper/counterweight, transmission side-frame guards, bottom guards, standard tires, full fuel tank, and 79-kg (175 lb) operator.



House Weatherization

SCOPE OF WORK

PROJECT TITLE: Housing Repair & Weatherization Project **DATE:** August 11, 2023

PROJECT LOCATION: Navajo Nation- Teesto Chapter

CONTRACTOR/VENDOR: Depending on the registered community member's quotes.

=====

PROJECT DESCRIPTION and PROJECT INTRODUCTION:

Teesto community members will benefit this funding with housing repairs and weatherization. It will improve the quality of life, have a safe sanitary home to ensure physical, emotional, and mental health to recover from COVID-19. The homes will be improved for adequate and stainable living.

The housing repair and weatherization project will assist Teesto registered residents with housing materials to improve and provide adequate living for local residents. This project will restore renovated & weatherized damaged home and homes in poor living conditions. Each household will provide three cost estimates, scope of work prior to purchasing housing materials. Home improvement will include roofing repair, interior & exterior walls, replacements of windows, interior & exterior doors, interiors walls, flooring, house wiring, plumbing, heating stove, heating & cooling system, and ADA ramps for door entrance.

SCOPE OF WORK:

To purchase housing materials for 300 homes, that are occupied year-round at \$3,000.00 to \$5,000.00 per home depending on the condition of the home. The homes will come with scope of work when the Teesto registered voter brings in the ARPA Housing Repair & Weatherization Application with three price quotes.

To purchase:

- Exterior doors with necessities
- Heavy duty security doors
- Interior doors with necessities
- Windows (Different sizes)
- 2X4's, 2X6's, 2X8's, 2X10's lumbers
- 2X4's, 2X6's, 2X8's green boards
- Drywalls
- Green board for drywalls
- Insulations (Different size)
- Joint compounds
- Interior & Exterior paints
- Corner beads
- 1/2", 1" OSB's
- Plumbing supplies
- Electric supplies
- Walk-in showers with necessities
- Kitchen sink with necessities
- Bathroom sink with necessities
- Wood stove
- Stove pipes
- Pellet stoves
- Refrigerators
- Range stoves
- Shingles
- Toilet bowl with necessities
- Baseboards

- Sidings
- Trimming boards
- Fascia boards
- Nails (Different size)
- Screws (Different size)
- Mineral roofing
- Felt papers

- Ductless Aire Air conditioner and Heating
- Taping
- Roofing cement
- Caulking
- Floor tiles
- Floor adhesive
- All necessities to repair & weatherize a home

Hired contractor or personnel will work on the scope of work for each home. The contractor or personnel will repair and weatherized the homes that have housing materials and replace and setup appliance or appliances of each home scope of work.

Appendix B

Budgets

John Deere 724P (6.1)

FY 2023

THE NAVAJO NATION
PROGRAM BUDGET SUMMARY

Page 01 of 06
BUDGET FORM 1

PART I. Business Unit No.: <u>NEW</u>		Program Title: <u>TEESTO CHAPTER</u> <i>Front End Loader</i>		Division/Branch: <u>NNDCD</u>				
Prepared By: <u>Clara Tsosie</u>		Phone No.: <u>928-657-8042</u>		Email Address: <u>teesto@navajochapters.org</u>				
PART II. FUNDING SOURCE(S)	Fiscal Year /Term	Amount	% of Total	PART III. BUDGET SUMMARY	Fund Type Code	(A) NNC Approved Original Budget	(B) Proposed Budget	(C) Difference or Total
6.1 Purchase new John Deere 724P <i>FILE</i>	05/22/23-12/31/23	541,746.30	100%	2001 Personnel Expenses				
				3000 Travel Expenses				
				3500 Meeting Expenses				
				4000 Supplies				
				5000 Lease and Rental				
				5500 Communications and Utilities				
				6000 Repairs and Maintenance				
				6500 Contractual Services				
				7000 Special Transactions				
				8000 Public Assistance				
				9000 Capital Outlay	6		\$ 541,746.30	
				9500 Matching Funds				
				9500 Indirect Cost				
				TOTAL		\$0.00	\$ 541,746.30	0
TOTAL: \$541,746.30 100%				PART IV. POSITIONS AND VEHICLES		(D)	(E)	
				Total # of Positions Budgeted:			0	
				Total # of Vehicles Budgeted:			0	
PART V. I HEREBY ACKNOWLEDGE THAT THE INFORMATION CONTAINED IN THIS BUDGET PACKAGE IS COMPLETE AND ACCURATE.								
SUBMITTED BY: <u>James Adakai, Acting Program Manager</u>				APPROVED BY: <u>Calvin Castillo, Executive Director</u>				
Program Manager's Printed Name				Division Director / Branch Chief's Printed Name				
<i>[Signature]</i> <u>6-5-23</u>				<i>[Signature]</i> <u>6-5-23</u>				
Program Manager's Signature and Date				Division Director / Branch Chief's Signature and Date				

THE NAVAJO NATION
PROGRAM PERFORMANCE CRITERIA

PART I. PROGRAM INFORMATION:									
Business Unit No.: <u>NEW</u>		Program Name/Title: <u>TEESTO CHAPTER</u>				<i>Front End Loader</i>			
PART II. PLAN OF OPERATION/RESOLUTION NUMBER/PURPOSE OF PROGRAM: TEESTO CHAPTER RESOLUTION NO.: TEE-MAR-14-2023									
PART III. PROGRAM PERFORMANCE CRITERIA:									
		1st QTR		2nd QTR		3rd QTR		4th QTR	
		Goal	Actual	Goal	services	Goal	Actual	Goal	Actual
1. Goal Statement: <u>To provide services to our community for clearing graveside, remove debris, and make road pass</u>									
Program Performance Measure/Objective: <u>To services the Teesto Community Center for any essential services.</u>		1		1		1		1	
2. Goal Statement: _____									
Program Performance Measure/Objective: _____									
3. Goal Statement: _____									
Program Performance Measure/Objective: _____									
4. Goal Statement: _____									
Program Performance Measure/Objective: _____									
5. Goal Statement: _____									
Program Performance Measure/Objective: _____									
PART IV. I HEREBY ACKNOWLEDGE THAT THE ABOVE INFORMATION HAS BEEN THOROUGHLY REVIEWED.									
James Adakai, Acting Program Manager					Calvin Castillo, Executive Director				
_____ Program Manager's Printed Name					_____ Division Director/Branch Chief's Printed Name				
_____ Program Manager's Signature and Date <i>6-5-23</i>					_____ Division Director/Branch Chief's Signature and Date <i>6-5-23</i>				

FY 2023

THE NAVAJO NATION
DETAILED BUDGET AND JUSTIFICATION

Page 04 of 06
BUDGET FORM 4

PART I. PROGRAM INFORMATION:			
Program Name/Title: <u>TEESTO CHAPTER <i>Front End Loader</i></u>		Business Unit No.: <u>NEW</u>	
PART II. DETAILED BUDGET:			
(A)	(B)	(C)	(D)
Object Code (LOD 6)	Object Code Description and Justification (LOD 7)	Total by DETAILED Object Code (LOD 6)	Total by MAJOR Object Code (LOD 4)
9000	CAPITAL OUTLAY		\$ 541,748.35
6	9140 EQUIPMENT	\$ 541,748.35	
	9142 EQUIPMENT: PURCHASE NEW John Deere 724P		
	Purchase to be made by December 2023		
		TOTAL \$	\$ 541,748.35

**THE NAVAJO NATION
PROJECT BUDGET SCHEDULE**

PART I. Business Unit No.: <u>NEW</u> Project Title: <u>TEESTO CHAPTER APRA PROJECT PER CJY-41-21</u> <i>Front End Loader</i> Project Description: <u>PURCHASE NEW JOHN DEERE 724P</u>														PART II. Project Information Project Type: <u>9142 EQUIPMENT</u> Planned Start Date: <u>5/22/2023</u> Planned End Date: <u>12/31/2026</u> Project Manager: <u>Clara Tsosie</u>																				
Check one box: <input checked="" type="checkbox"/> Original Budget <input type="checkbox"/> Budget Revision <input type="checkbox"/> Budget Reallocation <input type="checkbox"/> Budget Modification																																		
PART III. List Project Task separately, such as Plan, Design, Construct, Equip or Furnish.		PART IV. Use Fiscal Year (FY) Quarters to complete the information below. O = Oct.; N = Nov.; D = Dec., etc.																				Expected Completion Date if project exceeds 8 FY Qtrs.												
		FY 2024										FY 2025																						
		1st Qtr.			2nd Qtr.			3rd Qtr.			4th Qtr.			1st Qtr.			2nd Qtr.			3rd Qtr.			4th Qtr.			Date								
		O	N	D	J	F	M	A	M	J	Jul	A	S	O	N	D	J	F	M	A	M	J	Jul	A	S	O	N	D	J	F	M			
9140 Equipment: Purchase new JOHN DEERE 724P		XX	XX	XX	XX	XX	XX																											
PART V. Expected Quarterly Expenditures		\$			\$			\$			\$			\$			\$			\$			PROJECT TOTAL											
		541,746.30																					\$541,746.20											

FOR OMB USE ONLY: Resolution No: _____ FMIS Set Up Date: _____ Company No: _____ OMB Analyst: _____

John Deere 324 G With Forklifts (6.1)



FY 2023

THE NAVAJO NATION
PROGRAM BUDGET SUMMARY

Page 01 of 06
BUDGET FORM 1

PART I. Business Unit No.: <u>NEW</u>		Program Title: <u>TEESTO CHAPTER Forklift</u>		Division/Branch: <u>NNDCD</u>				
Prepared By: <u>Clara Tsoste</u>		Phone No.: <u>928-857-8042</u>		Email Address: <u>teesto@navajochapters.org</u>				
PART II. FUNDING SOURCE(S)	Fiscal Year /Term	Amount	% of Total	PART III. BUDGET SUMMARY	Fund Type Code	(A) NNC Approved Original Budget	(B) Proposed Budget	(C) Difference or Total
6-1 Purchase John Deere 324G w/ Attachments Forks 48 <i>NWRF</i>	05/22/23 - 12/31/23	86,312.00	100%	2001 Personnel Expenses				
				3000 Travel Expenses				
				3500 Meeting Expenses				
				4000 Supplies				
				5000 Lease and Rental				
				5500 Communications and Utilities				
				6000 Repairs and Maintenance				
				6500 Contractual Services				
				7000 Special Transactions				
				8000 Public Assistance				
				9000 Capital Outlay	6		\$ 86,312.00	
				9500 Matching Funds				
				9500 Indirect Cost				
				TOTAL		\$0.00	\$ 86,312.00	0
TOTAL:				PART IV. POSITIONS AND VEHICLES		(D)	(E)	
		\$86,312.00	100%	Total # of Positions Budgeted:			0	
				Total # of Vehicles Budgeted:			0	
PART V. I HEREBY ACKNOWLEDGE THAT THE INFORMATION CONTAINED IN THIS BUDGET PACKAGE IS COMPLETE AND ACCURATE.								
SUBMITTED BY: <u>James Adakai, Acting Program Manager</u>				APPROVED BY: <u>Calvin Castillo, Executive Director</u>				
Program Manager's Printed Name				Division Director / Branch Chief's Printed Name				
<i>[Signature]</i> Program Manager's Signature and Date				<i>[Signature]</i> Division Director / Branch Chief's Signature and Date				

THE NAVAJO NATION
PROGRAM PERFORMANCE CRITERIA

PART I. PROGRAM INFORMATION:									
Business Unit No.: <u>NEW</u>		Program Name/Title:			Teesto Chapter <u>Fordleft</u>				
PART II. PLAN OF OPERATION/RESOLUTION NUMBER/PURPOSE OF PROGRAM: TEESTO CHAPTER RESOLUTION NO.: TEE-MAR-14-2023									
PART III. PROGRAM PERFORMANCE CRITERIA:									
		1st QTR		2nd QTR		3rd QTR		4th QTR	
		Goal	Actual	Goal	services	Goal	Actual	Goal	Actual
1. Goal Statement: <u>To provide services to our community for any large loads and unloading.</u>									
Program Performance Measure/Objective: <u>To services the Teesto Community Center for any essential services.</u>		1		1		1		1	
2. Goal Statement: <u></u>									
Program Performance Measure/Objective: <u></u>									
3. Goal Statement: <u></u>									
Program Performance Measure/Objective: <u></u>									
4. Goal Statement: <u></u>									
Program Performance Measure/Objective: <u></u>									
5. Goal Statement: <u></u>									
Program Performance Measure/Objective: <u></u>									
PART IV. I HEREBY ACKNOWLEDGE THAT THE ABOVE INFORMATION HAS BEEN THOROUGHLY REVIEWED.									
James Adakai, Acting Program Manager					Calvin Castillo, Executive Director				
_____ Program Manager's Printed Name					_____ Division Director/Branch Chief's Printed Name				
<u> 6-5-23</u>					<u> 6-5-23</u>				
Program Manager's Signature and Date					Division Director/Branch Chief's Signature and Date				

FY 2023

THE NAVAJO NATION
 DETAILED BUDGET AND JUSTIFICATION

Page 04 of 06
 BUDGET FORM 4

PART I. PROGRAM INFORMATION:			
Program Name/Title: <u>TEESTO CHAPTER Fortcliff</u>		Business Unit No.: <u>NEW</u>	
PART II. DETAILED BUDGET:			
(A)	(B)	(C)	(D)
Object Code (LOD 6)	Object Code Description and Justification (LOD 7)	Total by DETAILED Object Code (LOD 6)	Total by MAJOR Object Code (LOD 4)
9000 6	CAPITAL OUTLAY 9140 EQUIPMENT 9142 EQUIPMENT: PURCHASE NEW JOHN DEERE 324G WITH ATTACHMENT -NEW JRB 48FORKS PURCHASE TO BE MADE BY DECEMBER 2023.	86312.00	86312.00
TOTAL		86312.00	86312.00

**THE NAVAJO NATION
PROJECT BUDGET SCHEDULE**

PART I. Business Unit No.: <u>NEW</u> Project Title: <u>TEESTO CHAPTER APRA PROJECT PER CJY-41-21 Forklift</u> Project Description: <u>PURCHASE NEW JOHN DEERE 324G WITH ATTACHMENTS- FORKS48</u> Check one box: <input checked="" type="checkbox"/> Original Budget <input type="checkbox"/> Budget Revision <input type="checkbox"/> Budget Reallocation <input type="checkbox"/> Budget Modification													PART II. Project Information Project Type: <u>9142 EQUIPMENT</u> Planned Start Date: <u>5/22/2023</u> Planned End Date: <u>12/31/2026</u> Project Manager: <u>Clara Tsosie</u>																				
PART III. List Project Task separately, such as Plan, Design, Construct, Equip or Furnish.	PART IV. Use Fiscal Year (FY) Quarters to complete the information below. O = Oct.; N = Nov.; D = Dec., etc.																		Expected Completion Date if project exceeds 8 FY Qtrs.														
	FY 2024												FY 2025																				
	1st Qtr.			2nd Qtr.			3rd Qtr.			4th Qtr.			1st Qtr.			2nd Qtr.			3rd Qtr.			4th Qtr.			Date								
	O	N	D	J	F	M	A	M	J	Jul	A	S	O	N	D	J	F	M	A	M	J	Jul	A	S	O	N	D	J	F	M			
9140 Equipment: Purchase new JOHN DEERE 324G with attachment	XX	XX	XX	XX	XX	XX																											
PART V. Expected Quarterly Expenditures	\$			\$			\$			\$			\$			\$			\$			\$			PROJECT TOTAL								
	85,312.00																								\$86,312.00								

FOR OMB USE ONLY: Resolution No: _____ FMIS Set Up Date: _____ Company No: _____ OMB Analyst: _____

House Weatherization

FY 2023

THE NAVAJO NATION
PROGRAM BUDGET SUMMARY

Page 01 of 06
BUDGET FORM 1

PART I. Business Unit No.: NEW Program Title: TEESTO CHAPTER *Housing Repair* *Weatherization* Division/Branch: NNDCD

Prepared By: Clara Tsosie Phone No.: 928-657-8042 Email Address: teesto@navajochapters.org

PART II. FUNDING SOURCE(S)	Fiscal Year /Term	Amount	% of Total	PART III. BUDGET SUMMARY	Fund Type Code	(A) NNC Approved Original Budget	(B) Proposed Budget	(C) Difference or Total
Navajo Nation ARPA Funds <i>/FRF</i>	5/22/23-12/31/2023	\$ 1,132,410.03	100%	2001 Personnel Expenses	6		\$ 256,529.94	
				3000 Travel Expenses				
				3500 Meeting Expenses				
				4000 Supplies				
				5000 Lease and Rental				
				5500 Communications and Utilities				
				6000 Repairs and Maintenance				
				6500 Contractual Services				
				7000 Special Transactions				
				8000 Public Assistance	6		\$ 875,880.09	
				9000 Capital Outlay				
				9500 Matching Funds				
				9500 Indirect Cost				
				TOTAL		\$0.00	\$ 1,132,410.03	0
TOTAL: \$1,132,410.03 100%				PART IV. POSITIONS AND VEHICLES		(D)	(E)	
				Total # of Positions Budgeted:				
				Total # of Vehicles Budgeted:				

PART V. I HEREBY ACKNOWLEDGE THAT THE INFORMATION CONTAINED IN THIS BUDGET PACKAGE IS COMPLETE AND ACCURATE.

SUBMITTED BY: James Adakai, Acting Program Manager APPROVED BY: Calvin Castillo, Executive Director

Program Manager's Printed Name *Division Director / Branch Chief's Printed Name*

Program Manager's Signature and Date *6-5-23* *Division Director / Branch Chief's Signature and Date* *6-5-23*

THE NAVAJO NATION
PROGRAM PERFORMANCE CRITERIA

PART I. PROGRAM INFORMATION:
 Business Unit No.: NEW Program Name/Title: TEESTO CHAPTER Housing Repair + Weatherization

PART II. PLAN OF OPERATION/RESOLUTION NUMBER/PURPOSE OF PROGRAM:
TEE-MAR-14-2023

PART III. PROGRAM PERFORMANCE CRITERIA:	1st QTR		2nd QTR		3rd QTR		4th QTR	
	Goal	Actual	Goal	Actual	Goal	Actual	Goal	Actual
1. Goal Statement: <u>To conduct community housing needs assessment to develop priority list for 16 housing repairs</u> Program Performance Measure/Objective: <u>Review, evaluate, screen and select candidates for housing repairs</u>	30		30		30		30	
2. Goal Statement: <u>To develop a housing repair strategy.</u> Program Performance Measure/Objective: <u>Determine scope of work for each housing repair project and cost estimate.</u>	30		30		30		30	
3. Goal Statement: <u>To evaluate and select best possible vendor to procure materials</u> Program Performance Measure/Objective: <u>Contact 3 or more vendors for bulk purchase, transport, deliver and other cost.</u>	30		30		30		30	
4. Goal Statement: Program Performance Measure/Objective: 								
5. Goal Statement: Program Performance Measure/Objective: 								

PART IV. I HEREBY ACKNOWLEDGE THAT THE ABOVE INFORMATION HAS BEEN THOROUGHLY REVIEWED.

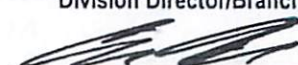
<u>James Adakai, Acting Program Manager</u> Program Manager's Printed Name  Program Manager's Signature and Date <u>6-5-23</u>	<u>Calvin Castillo, Executive Director</u> Division Director/Branch Chief's Printed Name  Division Director/Branch Chief's Signature and Date <u>6-5-23</u>
---	--

THE NAVAJO NATION
DETAILED BUDGET AND JUSTIFICATION

PART I. PROGRAM INFORMATION:				
Program Name/Title:		TEESTO CHAPTER	<i>Housing Repair and Weatherization</i>	Business Unit No.: NEW
PART II. DETAILED BUDGET:				
(A)	(B)	(C)	(D)	
Object Code (LOD 6)	Object Code Description and Justification (LOD 7)	Total by DETAILED Object Code (LOD 6)	Total by MAJOR Object Code (LOD 4)	
6				
8000	PUBLIC ASSISTANCE		\$	875,880.09
8500	INFRASTURE (NON-CAP)	\$	875,880.09	
8510	Housing Construction Materials			
	Home repair and weatherization will include roofing repair, interior & exterior walls, replacement of windows, exterior & interior doors, interior & exterior walls, flooring, housewiring, plumbing, heating stove, and ADA ramps for entrance, if needed.			
2001	PERSONNEL EXPENSES		\$	48,535.80
6	CARPENTRY SUPERVISOR GRADE 62 STEP F	\$	48,535.80	
2310	2320 \$21.13/HOUR X 2088 HOURS X 01 PERSONNEL			
2900	2910 FICA: 6.20% = \$2,735.41			
	2914 MEDI: 1.45% = \$639.73			
	2951 SUTA: 1.83% = \$807.39			
	2960 WORKER COMP: = \$233.83			
6	CARPENTRY WORKERS GRADE: 60 STEP L		\$	207,994.14
2310	2320 \$18.11/HOUR X 2088 HOURS X 05 PERSONNEL	\$	207,994.14	
2900	2910 FICA: 6.20% = \$11,722.24			
	2914 MEDI: 1.45% = \$2,741.49			
	2951 SUTA: 1.83% = \$3,459.95			
	2960 WORKER COMP: = \$1,002.06			
TOTAL		\$	1,132,410.03	\$ 1,132,410.03

**THE NAVAJO NATION
PROJECT BUDGET SCHEDULE**

PART I. Business Unit No.: <u>NEW</u> Project Title: <u>TEESTO CHAPTER APRA PROJECT PER CYJ-41-21</u> Housing Repair + weatherization Project Description: <u>PURCHASE HOUSING MATERIALS WEATHERIZED HOMES.</u>													PART II. Project Information Project Type: <u>8500 Infrasture (non cap)</u> Planned Start Date: <u>5/22/2023</u> Planned End Date: <u>12/31/2026</u> Project Manager: <u>Clara Tsosie</u>																	
Check one box: <input checked="" type="checkbox"/> Original Budget <input type="checkbox"/> Budget Revision <input type="checkbox"/> Budget Reallocation <input type="checkbox"/> Budget Modification																														
PART III. List Project Task separately; such as Plan, Design, Construct, Equip or Furnish.	PART IV. Use Fiscal Year (FY) Quarters to complete the information below. O = Oct.; N = Nov.; D = Dec., etc.																		Expected Completion Date if project exceeds 8 FY Qtrs.											
	FY 2024												FY 2025												Date December 31, 2026					
	1st Qtr.			2nd Qtr.			3rd Qtr.			4th Qtr.			1st Qtr.			2nd Qtr.			3rd Qtr.			4th Qtr.			O	N	D	J	F	M
	O	N	D	J	F	M	A	M	J	Jul	A	S	O	N	D	J	F	M	A	M	J	Jul	A	S	O	N	D	J	F	M
8500 INFRASTURE (NON CAP) Purchase Housing Materials	1) PLANNING	xxxx	xxxx	xxxx	xxxx	xxxx	xxxx	xxxx	xxxx	xxxx	xxxx	xxxx	xxxx	xxxx	xxxx	xxxx	xxxx	xxxx	xxxx	xxxx	xxxx	xxxx	xxxx	xxxx	xxxx	xxxx	xxxx	xxxx		
2) DESIGN	xxxx	xxxx	xxxx	xxxx	xxxx	xxxx	xxxx	xxxx	xxxx	xxxx	xxxx	xxxx	xxxx	xxxx	xxxx	xxxx	xxxx	xxxx	xxxx	xxxx	xxxx	xxxx	xxxx	xxxx	xxxx	xxxx	xxxx			
3) PROCUREMENT	xxxx	xxxx	xxxx	xxxx	xxxx	xxxx	xxxx	xxxx	xxxx	xxxx	xxxx	xxxx	xxxx	xxxx	xxxx	xxxx	xxxx	xxxx	xxxx	xxxx	xxxx	xxxx	xxxx	xxxx	xxxx	xxxx	xxxx			
4) CONSTRUCTION	xxxx	xxxx	xxxx	xxxx	xxxx	xxxx	xxxx	xxxx	xxxx	xxxx	xxxx	xxxx	xxxx	xxxx	xxxx	xxxx	xxxx	xxxx	xxxx	xxxx	xxxx	xxxx	xxxx	xxxx	xxxx	xxxx	xxxx			
PART V. Expected Quarterly Expenditures	\$			\$			\$			\$			\$			\$			\$			\$			PROJECT TOTAL					
	566,205.02												566,205.02												\$1,132,410.04					

FOR OMB USE ONLY: Resolution No: _____ FMIS Set Up Date: _____ Company No: _____ OMB Analyst: _____

Appendix C

Disbursement Schedule

SUBRECIPIENT AGREEMENT

Between

THE NAVAJO NATION

And

Teesto Chapter

Appendix C

Disbursement Schedule

The Navajo Nation will make an initial disbursement to the Teesto Chapter from the following K-accounts, of 50% of the total amount, then 25% for the second and third disbursements.

	K2115391 John Deere 724P	K2115392 John Deere 324G w forklift	K2115394 House repair - weatherization
1st Disbursement at 50%	\$ 270,873.00	\$ 43,156.00	\$ 566,205.00
2nd Disbursement at 25%	\$ 135,436.50	\$ 21,578.00	\$ 283,102.50
3rd Disbursement at 25%	\$ 135,436.50	\$ 21,578.00	\$ 283,102.50

\$ 541,746.00 \$ 86,312.00 \$ 1,132,410.00

*In accordance with this Subrecipient Agreement, paragraph 6, "The SUBRECIPIENT must provide documentation that it has obligated or expended 75% of its prior disbursement installment before OOC will release the next disbursement installment. If the SUBRECIPIENT expends 75% of its disbursement installment prior to the end of a twelve-month period, the SUBRECIPIENT may request to the FRF Office, the Administrative Oversight, and OOC that OOC release the next disbursement installment prior to the end of that twelve-month period."

Concurrence:



Arbin Mitchell, Division Director
Navajo Nation Division of Community Development

Appendix D

Expenditure

Plans

John Deere 324 G With Forklifts (6.1)



NAVAJO NATION DEPARTMENT OF JUSTICE
OFFICE OF THE ATTORNEY GENERAL

ETHEL B. BRANCH
Attorney General

HEATHER CLAH
Deputy Attorney General

DEPARTMENT OF JUSTICE
INITIAL ELIGIBILITY DETERMINATION
FOR NAVAJO NATION FISCAL RECOVERY FUNDS

RFS/HK Review #: HK0533

Date & Time Received: 06/07/23 at 09:14

Date & Time of Response: 06/16/23 at 17:00

Entity Requesting FRF: Teesto Chapter

Title of Project: John Deere 324G with JRB 48FORKS - Forklift

Administrative Oversight: Division of Community Development

Amount of Funding Requested: \$86,312.00

Eligibility Determination:

- FRF eligible
FRF ineligible
Additional information requested

FRF Eligibility Category:

- (1) Public Health and Economic Impact
(2) Premium Pay
(3) Government Services/Lost Revenue
(4) Water, Sewer, Broadband Infrastructure

U.S. Department of Treasury Reporting Expenditure Category:

6.1: Provision of Government Services

Returned for the following reasons (Ineligibility Reasons/Paragraphs 5.E.(1)-(10) of FRF Procedures):

- | | |
|--|--|
| <input type="checkbox"/> Missing Form | <input type="checkbox"/> Expenditure Plan incomplete |
| <input type="checkbox"/> Supporting documentation missing | <input type="checkbox"/> Funds will not be obligated by 12/31/2024 |
| <input type="checkbox"/> Project will not be completed by 12/31/2026 | <input type="checkbox"/> Incorrect Signatory |
| <input type="checkbox"/> Ineligible purpose | <input type="checkbox"/> Inconsistent with applicable NN or federal laws |
| <input type="checkbox"/> Submitter failed to timely submit CARES reports | |
| <input type="checkbox"/> Additional information submitted is insufficient to make a proper determination | |

Other Comments: _____

Name of DOJ Reviewer: MacArthur Stant

Signature of DOJ Reviewer: _____

Disclaimers:
If additional information has been requested and you wish to provide it, please resubmit all the required forms updated to include the additional information. Full resubmission will expedite the Initial Eligibility Determination process. Therefore, please include a new RFS form indicating resubmission, revised Appendix A, Budget Form 1, and other supporting documents. **Please email your resubmission to arpa@nndoj.org.** Please be aware that under Resolution BFS-31-21 a Project or Program can only be reviewed twice, therefore it is critical that you include all the requested additional information for your second submission.

An NNDOJ Initial Eligibility Determination is based on the documents provided, which NNDOJ will assume are true, correct, and complete. Should the Project or Program change in any material way after the initial determination, the requestor must seek the advice of NNDOJ. An initial determination is limited to review of the Project or Program as it relates to whether the Project or Program is a legally allowable use – it does not serve as an opinion as to whether or not the Project or Program should be funded, nor does it serve as an opinion as to whether or not the amount requested is reasonable or accurate.

THE NAVAJO NATION
FISCAL RECOVERY FUNDS REQUEST FORM & EXPENDITURE PLAN
FOR GOVERNANCE-CERTIFIED CHAPTERS

Part 1. Identification of parties.

Governance-Certified Chapter requesting FRF: TEESTO CHAPTER Date prepared: 05/22/23

Chapter's mailing address: Teesto Chapter PO Box 7385 phone & email: (928)657-8042
website (if any): teesto@navajochapters.org

This Form prepared by: Clara Tsosie, Chapter Manager phone/email: (928)657-8042
c_tsosie@nnchapters.org
CONTACT PERSON'S name and title CONTACT PERSON'S info

Title and type of Project: John Deere 324G with JRB 48FORKS - Forklift

Chapter President: Elmer Clark phone & email: 928-606-4136 & clark_elmer@yahoo.com

Chapter Vice-President: Leroy Thomas phone & email: 928-589-7154

Chapter Secretary: Sophia Francis phone & email: 928-313-0529 & sophiafrancis@navajochapters.org

Chapter Treasurer: Sophia Francis phone & email: 928-313-0529 & sophiafrancis@navajochapters.org

Chapter Manager or CSC: Clara Tsosie phone & email: 928-657-8045 & c_tsosie@nnchapters.org

DCD/Chapter ASO: Toni Mina, ASO phone & email: 928-654-3934 & tmina@nndcd.org

List types of Subcontractors or Subrecipients that will be paid with FRF (if known): Purchase a John Deere 324G with Attachment - New JRB 48FORKS document attached

Amount of FRF requested: \$86,312.00 FRF funding period: 05/22/2023 - 12/31/2026
indicate Project starting and ending/deadline date

Part 2. Expenditure Plan details.

(a) Describe the Program(s) and/or Project(s) to be funded, including how the funds will be used, for what purposes, the location(s) to be served, and what COVID-related needs will be addressed:

Purchase John Deere 324G with JRB 48FORKS. Purchase the equipment to be utilized for bulk unloading and loading for community needs such as food, PPE's and all necessary items for a recovery plan. document attached

(b) Explain how the Program or Project will benefit the Navajo Nation, Navajo communities, or the Navajo People:

How the purchase of the equipment is going to benefit the Teesto community is to unload and load these bulk orders. document attached

(c) A prospective timeline showing the estimated date of completion of the Project and/or each phase of the Project. Disclose any challenges that may prevent you from incurring costs for all funding by December 31, 2024 and/or fully expending funds and completing the Program(s) or Project(s) by December 31, 2026:

The purchase will be made through RDO Equipment Company with Buzz Ivcek, Sales Professional. Purchase will be made about December 31, 2024.

document attached

(d) Identify who will be responsible for implementing the Program or Project:

Clara Tsosie, Chapter Manager

document attached

(e) Explain who will be responsible for operations and maintenance costs for the Project once completed, and how such costs will be funded prospectively:

Teesto Chapter will be responsible for operation & maintenance costs. The funds that will be the Chapter annual budget.

document attached

(f) State which of the 66 Fiscal Recovery Fund expenditure categories in the attached U.S. Department of the Treasury Appendix 1 listing the proposed Program or Project falls under, and explain the reason why:

6.10 Teesto Chapter would utilize this equipment to distribute food and other bulk orders for this recovery plan.

document attached

Part 3. Additional documents.

List here all additional supporting documents attached to this FRF Expenditure Plan (or indicate N/A):

- 1. Budget Forms
- 2. Cost estimate
- 3. Chapter Resolution

Chapter Resolution attached

Part 4. Affirmation by Funding Recipient.

Funding Recipient affirms that its receipt of Fiscal Recovery Funds and the implementation of this FRF Expenditure Plan shall be in accordance with Resolution No. CJY-41-21, the ARPA, ARPA Regulations, and with all applicable federal and Navajo Nation laws, regulations, and policies:

Chapter's Preparer: 
signature of Preparer/CONTACT PERSON

Approved by: 
signature of Chapter President (or Vice-President)

Approved by: 
signature of Chapter Manager or CSC

Approved by: Tori Mueni ASO
signature of DCD/Chapter ASO

Approved to submit for Review: 
signature of DCD Director

FY 2023

THE NAVAJO NATION
PROGRAM BUDGET SUMMARY

Page 01 of 06
BUDGET FORM 1

PART I. Business Unit No.: <u>NEW</u>		Program Title: <u>TEESTO CHAPTER <i>Forklift</i></u>		Division/Branch: <u>NNDCD</u>	
Prepared By: <u>Clara Tsosie</u>		Phone No.: <u>928-657-8042</u>		Email Address: <u>teesto@navajochapters.org</u>	

PART II. FUNDING SOURCE(S)	Fiscal Year /Term	Amount	% of Total	PART III. BUDGET SUMMARY	Fund Type Code	(A) NNC Approved Original Budget	(B) Proposed Budget	(C) Difference or Total
6.1 Purchase John Deere 324G w/ attachments Forks 48 <i>NWFF</i>	05/22/23 - 12/31/26	86,312.00	100%	2001 Personnel Expenses				
				3000 Travel Expenses				
				3500 Meeting Expenses				
				4000 Supplies				
				5000 Lease and Rental				
				5500 Communications and Utilities				
				6000 Repairs and Maintenance				
				6500 Contractual Services				
				7000 Special Transactions				
				8000 Public Assistance				
				9000 Capital Outlay	6		\$ 86,312.00	
				9500 Matching Funds				
				9500 Indirect Cost				
				TOTAL		\$0.00	\$ 86,312.00	0

PART IV. POSITIONS AND VEHICLES	(D)	(E)
Total # of Positions Budgeted:		0
Total # of Vehicles Budgeted:		0

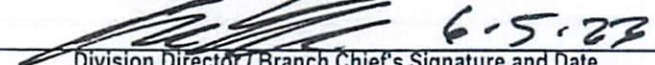
PART V. I HEREBY ACKNOWLEDGE THAT THE INFORMATION CONTAINED IN THIS BUDGET PACKAGE IS COMPLETE AND ACCURATE.	
SUBMITTED BY: <u>James Adakai, Acting Program Manager</u> Program Manager's Printed Name  Program Manager's Signature and Date	APPROVED BY: <u>Calvin Castillo, Executive Director</u> Division Director / Branch Chief's Printed Name  Division Director / Branch Chief's Signature and Date

THE NAVAJO NATION
PROGRAM PERFORMANCE CRITERIA

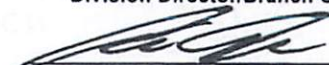
PART I. PROGRAM INFORMATION:									
Business Unit No.: <u>NEW</u>			Program Name/Title: <u>Teesto Chapter Forklift</u>						
PART II. PLAN OF OPERATION/RESOLUTION NUMBER/PURPOSE OF PROGRAM: <u>TEESTO CHAPTER RESOLUTION NO.: TEE-MAR-14-2023</u>									
PART III. PROGRAM PERFORMANCE CRITERIA:									
		1st QTR		2nd QTR		3rd QTR		4th QTR	
		Goal	Actual	Goal	ervices	Goal	Actual	Goal	Actual
1. Goal Statement: <u>To provide services to our community for any large loads and unloading.</u>									
Program Performance Measure/Objective: <u>To services the Teesto Community Center for any essential services.</u>		1		1		1		1	
2. Goal Statement:									
Program Performance Measure/Objective:									
3. Goal Statement:									
Program Performance Measure/Objective:									
4. Goal Statement:									
Program Performance Measure/Objective:									
5. Goal Statement:									
Program Performance Measure/Objective:									
PART IV. I HEREBY ACKNOWLEDGE THAT THE ABOVE INFORMATION HAS BEEN THOROUGHLY REVIEWED.									
James Adakai, Acting Program Manager				Calvin Castillo, Executive Director					
_____ Program Manager's Printed Name				_____ Division Director/Branch Chief's Printed Name					
 <u>6-5-23</u>				 <u>6-5-23</u>					
_____ Program Manager's Signature and Date				_____ Division Director/Branch Chief's Signature and Date					

THE NAVAJO NATION
DETAILED BUDGET AND JUSTIFICATION

PART I. PROGRAM INFORMATION:			
Program Name/Title: _____		TEESTO CHAPTER <i>Forklift</i>	Business Unit No.: _____
PART II. DETAILED BUDGET:			
(A)	(B)	(C)	(D)
Object Code (LOD 6)	Object Code Description and Justification (LOD 7)	Total by DETAILED Object Code (LOD 6)	Total by MAJOR Object Code (LOD 4)
9000 6	CAPITAL OUTLAY 9140 EQUIPMENT 9142 EQUIPMENT: PURCHASE NEW JOHN DEERE 324G WITH ATTACHMENT -NEW JRB 48FORKS PURCHASE TO BE MADE BY DECEMBER 2023.	86312.00	86312.00
TOTAL		86312.00	86312.00

**THE NAVAJO NATION
PROJECT BUDGET SCHEDULE**

PART I. Business Unit No.: <u>NEW</u> Project Title: <u>TEESTO CHAPTER APRA PROJECT PER CJY-41-21 Forklift</u> Project Description: <u>PURCHASE NEW JOHN DEERE 324G WITH ATTACHMENTS- FORKS48</u>												PART II. Project Information Project Type: <u>9142 EQUIPMENT</u> Planned Start Date: <u>5/22/2023</u> Planned End Date: <u>12/31/2026</u> Project Manager: <u>Clara Tsosie</u>																			
Check one box: <input checked="" type="checkbox"/> Original Budget <input type="checkbox"/> Budget Revision <input type="checkbox"/> Budget Reallocation <input type="checkbox"/> Budget Modification																															
PART III. List Project Task separately; such as Plan, Design, Construct, Equip or Furnish.		PART IV. Use Fiscal Year (FY) Quarters to complete the information below. O = Oct.; N = Nov.; D = Dec., etc.																		Expected Completion Date if project exceeds 8 FY Qtrs.											
9140 Equipment: Purchase new JOHN DEERE 324G with attachment		FY 2024									FY 2025									Date											
		1st Qtr.			2nd Qtr.			3rd Qtr.			4th Qtr.			1st Qtr.			2nd Qtr.			3rd Qtr.			4th Qtr.			Date					
		O XX	N XX	D XX	J XX	F XX	M XX	A	M	J	Jul	A	S	O	N	D	J	F	M	A	M	J	Jul	A	S	O	N	D	J	F	M
PART V.		S			S			S			S			S			S			S			PROJECT TOTAL								
Expected Quarterly Expenditures		86,312.00																					\$86,312.00								

FOR OMB USE ONLY: Resolution No: _____ FMIS Set Up Date: _____ Company No: _____ OMB Analyst: _____



Investment Proposal (Quote)

RDO Equipment Co.
 5500 East Penstock Avenue
 Flagstaff AZ, 86004
 Phone: (928) 526-0639 - Fax: (928) 526-2498

Proposal for:
 TEESTO CHAPTER OF THE NAV
 PO BOX 7385
 WINSLOW, AZ, 860477166
 NAVAJO

Investment Proposal Date: 5/8/2023
 Pricing Valid Until: 5/22/2023
 Deal Number: 1619003
 Customer Account#: 8042005
 Sales Professional: Buzz Ivicsek
 Phone: (928) 526-0639
 Fax: (928) 526-2498
 Email: Blvicek@rdoequipment.com

Comments

POSSIBLE 3-5% PRICE INCREASE WITHIN THE NEXT 3-6 MONTHS.

Equipment Information

Quantity	Serial Number Stock Number	Hours (approx.)	Status / Year / Make / Model Additional Items	Cash Price
1	TBD TBD	0	New 2023 JOHN DEERE 324G	\$78,800.00
			Customer Discount SOURCEWELL 30%	(\$21,598.50)
			Item Subtotal:	\$57,201.50
1	82997 X486666	0	Attachment - New 2021 ARROW MATERIAL HANDLING PRODUCTS FORKS48	\$960.00
			Equipment Subtotal:	\$58,161.50

Purchase Order Totals

Balance:	\$58,161.50
AZ STATE TAX:	\$3,489.69
AZ COUNTY TAX:	\$0.00
AZ CITY TAX:	\$0.00
Sales Tax Total:	\$3,489.69
Sub Total:	\$61,651.19
Cash with Order:	\$0.00
Balance Due:	\$61,651.19

Equipment Options

Qty	Serial Number	Year / Make / Model	Description
1	TBD	2023 JOHN DEERE 324G	00C2T 324G SKID STEER 0722 Open ROPS. Manual QT. SL. 250: 1301 Engine - Turbocharged 8050 Cold Start Package 8080 Engine Air Pre cleaner 1501 English Operator's Manual and Decals 170K JDLink™ 2315 12 X 16.5 NHS, CAMSO SKS 0950 E-H (ISO Pattern) Joystick Controls 6001 Mechanical Suspension Seat (Vinyl) 4000 2-Inch Seat Belt 8380 Footrest with Floor mat 9041 72 in. Construction Bucket (17.8 cu. ft.) with Edge
1	82997	2021 ARROW MATERIAL HANDLING PRODUCTS FORKS48	1.5X4X48 48" FORK TINES

John Deere 724P (6.1)



NAVAJO NATION DEPARTMENT OF JUSTICE
OFFICE OF THE ATTORNEY GENERAL

ETHEL B. BRANCH
Attorney General

HEATHER CLAH
Deputy Attorney General

DEPARTMENT OF JUSTICE
INITIAL ELIGIBILITY DETERMINATION
FOR NAVAJO NATION FISCAL RECOVERY FUNDS

RFS/HK Review #: HK0534

Date & Time Received: 06/07/23 at 09:26

Date & Time of Response: 6/12/23 at 15:53

Entity Requesting FRF: Teesto Chapter

Title of Project: New John Deere 724P

Administrative Oversight: DCD

Amount of Funding Requested: \$541,746.00

Eligibility Determination:

- FRF eligible
 FRF ineligible
 Additional information requested

FRF Eligibility Category:

- (1) Public Health and Economic Impact
 (3) Government Services/Lost Revenue
 (2) Premium Pay
 (4) Water, Sewer, Broadband Infrastructure

U.S. Department of Treasury Reporting Expenditure Category: _____

6.1: Provision of Government Services

Returned for the following reasons (Ineligibility Reasons/Paragraphs 5.E.(1)-(10) of FRF Procedures):

- | | |
|--|--|
| <input type="checkbox"/> Missing Form | <input type="checkbox"/> Expenditure Plan incomplete |
| <input type="checkbox"/> Supporting documentation missing | <input type="checkbox"/> Funds will not be obligated by 12/31/2024 |
| <input type="checkbox"/> Project will not be completed by 12/31/2026 | <input type="checkbox"/> Incorrect Signatory |
| <input type="checkbox"/> Ineligible purpose | <input type="checkbox"/> Inconsistent with applicable NN or federal laws |
| <input type="checkbox"/> Submitter failed to timely submit CARES reports | |
| <input type="checkbox"/> Additional information submitted is insufficient to make a proper determination | |

Other Comments: _____

Name of DOJ Reviewer: Rudy Anaya, Tax and Finance Unit

Signature of DOJ Reviewer: _____

Disclaimers:

If additional information has been requested and you wish to provide it, please resubmit all the required forms updated to include the additional information. Full resubmission will expedite the Initial Eligibility Determination process. Therefore, please include a new RFS form indicating resubmission, revised Appendix A, Budget Form 1, and other supporting documents. **Please email your resubmission to arpa@nndoj.org.** Please be aware that under Resolution BFS-31-21 a Project or Program can only be reviewed twice, therefore it is critical that you include all the requested additional information for your second submission.

An NNDOJ Initial Eligibility Determination is based on the documents provided, which NNDOJ will assume are true, correct, and complete. Should the Project or Program change in any material way after the initial determination, the requestor must seek the advice of NNDOJ. An initial determination is limited to review of the Project or Program as it relates to whether the Project or Program is a legally allowable use – it does not serve as an opinion as to whether or not the Project or Program should be funded, nor does it serve as an opinion as to whether or not the amount requested is reasonable or accurate.

**THE NAVAJO NATION
FISCAL RECOVERY FUNDS REQUEST FORM & EXPENDITURE PLAN
FOR GOVERNANCE-CERTIFIED CHAPTERS**

Part 1. Identification of parties.

Governance-Certified Chapter requesting FRF: TEESTO CHAPTER Date prepared: 05/22/2023

Chapter's mailing address: Teesto Chapter PO Box 7385, Winslow, Arizona 86047 phone & email: 928-657-8042 & teesto@navajochapters.org website (if any): teesto@navajochapters.org

This Form prepared by: Clara Tsosie, Chapter Manager phone/email: 928-657-8042

CONTACT PERSON'S name and title

c_tsosie@nnchapters.org
CONTACT PERSON'S info

Title and type of Project: New John Deere 724P

Chapter President: Elmer Clark phone & email: 928-606-4136 & clark_elmer@yahoo.com

Chapter Vice-President: Leroy Thomas phone & email: 928-589-7154

Chapter Secretary: Sophia Francis phone & email: 928-313-0528 & sophiafrancis@navajochapters.org

Chapter Treasurer: Sophia Francis phone & email: 928-313-0528 & sophiafrancis@navajochapters.org

Chapter Manager or CSC: Clara Tsosie phone & email: 928-657-8042 & c_tsosie@nnchapters.org

DCD/Chapter ASO: Toni Mina phone & email: 928-654-3934 & tmina@nndcd.org

List types of Subcontractors or Subrecipients that will be paid with FRF (if known): _____

document attached

Amount of FRF requested: \$541,746.00 FRF funding period: 05/22/2022 - 12/31/2026
indicate Project starting and ending/deadline date

Part 2. Expenditure Plan details.

(a) Describe the Program(s) and/or Project(s) to be funded, including how the funds will be used, for what purposes, the location(s) to be served, and what COVID-related needs will be addressed:

Purchase new John Deere 724P. Purchase the equipment to be utilized for removing and grade soil for services. This project will provide end of life services to Teesto community members.

document attached

(b) Explain how the Program or Project will benefit the Navajo Nation, Navajo communities, or the Navajo People:

How the Navajo Nation, Teesto community and our registered and community members will benefit of this equipment is to clear and debris around the graveside.

document attached

(c) A prospective timeline showing the estimated date of completion of the Project and/or each phase of the Project. Disclose any challenges that may prevent you from incurring costs for all funding by December 31, 2024 and/or fully expending funds and completing the Program(s) or Project(s) by December 31, 2026:

Purchase will be made through RDO Equipment Company with Buzz Ivcek. Purchase will be made before December 31, 2026.

document attached

(d) Identify who will be responsible for implementing the Program or Project:

Clara Tsosie, Chapter Manager

document attached

(e) Explain who will be responsible for operations and maintenance costs for the Project once completed, and how such costs will be funded prospectively:

Teesto Chapter will be responsible for operation & maintenance costs. The funds that will be the Chapter annual budget.

document attached

(f) State which of the 66 Fiscal Recovery Fund expenditure categories in the attached U.S. Department of the Treasury Appendix 1 listing the proposed Program or Project falls under, and explain the reason why:

6.1 Teesto Chapter will be utilize this equipment to remove debris around the graveside.

document attached

Part 3. Additional documents.

List here all additional supporting documents attached to this FRF Expenditure Plan (or indicate N/A):

- 1. Budget Forms
- 2. Cost Estimate
- 3. Chapter Resolution

Chapter Resolution attached

Part 4. Affirmation by Funding Recipient.

Funding Recipient affirms that its receipt of Fiscal Recovery Funds and the implementation of this FRF Expenditure Plan shall be in accordance with Resolution No. CJY-41-21, the ARPA, ARPA Regulations, and with all applicable federal and Navajo Nation laws, regulations, and policies:

Chapter's Preparer:  signature of Preparer/CONTACT PERSON

Approved by:  signature of Chapter President (or Vice-President)

Approved by:  signature of Chapter Manager or CSC



Approved by: Tom Mera, ASO signature of DCD/Chapter ASO

Approved to submit for Review:  signature of DCD Director

FY 2023

THE NAVAJO NATION
PROGRAM BUDGET SUMMARY

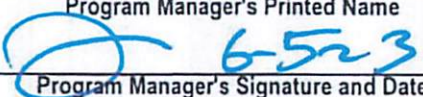
Page 01 of 06
BUDGET FORM 1

PART I. Business Unit No.: <u>NEW</u>		Program Title: <u>TEESTO CHAPTER <i>Front End Leader</i></u>		Division/Branch: <u>NNDCCD</u>				
Prepared By: <u>Clara Tsosie</u>		Phone No.: <u>928-657-8042</u>		Email Address: <u>teesto@navajochapters.org</u>				
PART II. FUNDING SOURCE(S)	Fiscal Year /Term	Amount	% of Total	PART III. BUDGET SUMMARY	Fund Type Code	(A) NNC Approved Original Budget	(B) Proposed Budget	(C) Difference or Total
6.1 <i>725</i> Purchase new John Deere 724P	05/22/23-12/31/25	541,746.30	100%	2001 Personnel Expenses				
				3000 Travel Expenses				
				3500 Meeting Expenses				
				4000 Supplies				
				5000 Lease and Rental				
				5500 Communications and Utilities				
				6000 Repairs and Maintenance				
				6500 Contractual Services				
				7000 Special Transactions				
				8000 Public Assistance				
				9000 Capital Outlay	6		\$ 541,746.30	
				9500 Matching Funds				
				9500 Indirect Cost				
				TOTAL		\$0.00	\$ 541,746.30	0
TOTAL: \$541,746.30 100%				PART IV. POSITIONS AND VEHICLES		(D)	(E)	
				Total # of Positions Budgeted:			0	
				Total # of Vehicles Budgeted:			0	
PART V. I HEREBY ACKNOWLEDGE THAT THE INFORMATION CONTAINED IN THIS BUDGET PACKAGE IS COMPLETE AND ACCURATE.								
SUBMITTED BY: <u>James Adakai, Acting Program Manager</u>				APPROVED BY: <u>Calvin Castillo, Executive Director</u>				
Program Manager's Printed Name				Division Director / Branch Chief's Printed Name				
 6-5-23				 6-5-23				
Program Manager's Signature and Date				Division Director / Branch Chief's Signature and Date				

THE NAVAJO NATION
PROGRAM PERFORMANCE CRITERIA

PART I. PROGRAM INFORMATION:

Business Unit No.: NEW Program Name/Title: TEESTO CHAPTER Front End Loader

PART II. PLAN OF OPERATION/RESOLUTION NUMBER/PURPOSE OF PROGRAM:
TEESTO CHAPTER RESOLUTION NO.: TEE-MAR-14-2023

PART III. PROGRAM PERFORMANCE CRITERIA:	1st QTR		2nd QTR		3rd QTR		4th QTR	
	Goal	Actual	Goal	ervices	Goal	Actual	Goal	Actual
1. Goal Statement: <u>To provide services to our community for clearing graveside, remove debris, and make road pass</u> Program Performance Measure/Objective: <u>To services the Teesto Community Center for any essential services.</u>	1		1		1		1	
2. Goal Statement: Program Performance Measure/Objective:								
3. Goal Statement: Program Performance Measure/Objective:								
4. Goal Statement: Program Performance Measure/Objective:								
5. Goal Statement: Program Performance Measure/Objective:								

PART IV. I HEREBY ACKNOWLEDGE THAT THE ABOVE INFORMATION HAS BEEN THOROUGHLY REVIEWED.

<p>James Adakai, Acting Program Manager _____ Program Manager's Printed Name</p> <p style="text-align: center; color: blue;">6-5-23</p> <p>_____ Program Manager's Signature and Date</p>	<p>Calvin Castillo, Executive Director _____ Division Director/Branch Chief's Printed Name</p> <p style="text-align: center; color: blue;">6-5-23</p> <p>_____ Division Director/Branch Chief's Signature and Date</p>
---	--

THE NAVAJO NATION
 DETAILED BUDGET AND JUSTIFICATION

PART I. PROGRAM INFORMATION:			
Program Name/Title: _____		TEESTO CHAPTER <i>Front End Loader</i>	Business Unit No.: _____ NEW
PART II. DETAILED BUDGET:			
(A)	(B)	(C)	(D)
Object Code (LOD 6)	Object Code Description and Justification (LOD 7)	Total by DETAILED Object Code (LOD 6)	Total by MAJOR Object Code (LOD 4)
9000 6	CAPITAL OUTLAY 9140 EQUIPMENT 9142 EQUIPMENT: PURCHASE NEW John Deere 724P Purchase to be made by December 2023	\$ 541,746.30	\$ 541,746.30
TOTAL		\$ 541,746.30	\$ 541,746.30

**THE NAVAJO NATION
PROJECT BUDGET SCHEDULE**

PART I. Business Unit No.: <u>NEW</u> Project Title: <u>TEESTO CHAPTER APRA PROJECT PER CJY-41-21</u> <i>Front End Loader</i> Project Description <u>PURCHASE NEW JOHN DEERE 724P</u>													PART II. Project Information Project Type: <u>9142 EQUIPMENT</u> Planned Start Date: <u>5/22/2023</u> Planned End Date: <u>12/31/2026</u> Project Manager: <u>Clara Tsosie</u>																																						
Check one box: <input checked="" type="checkbox"/> Original Budget <input type="checkbox"/> Budget Revision <input type="checkbox"/> Budget Reallocation <input type="checkbox"/> Budget Modification													PART III. List Project Task separately; such as Plan, Design, Construct, Equip or Furnish.													PART IV. Use Fiscal Year (FY) Quarters to complete the information below. O = Oct.; N = Nov.; D = Dec., etc.													Expected Completion Date if project exceeds 8 FY Qtrs.												
9140 Equipment: Purchase new JOHN DEERE 724P													FY 2024												FY 2025												Date														
													1st Qtr.			2nd Qtr.			3rd Qtr.			4th Qtr.			1st Qtr.			2nd Qtr.			3rd Qtr.			4th Qtr.			Date														
													O	N	D	J	F	M	A	M	J	Jul	A	S	O	N	D	J	F	M	A	M	J	Jul	A	S	O	N	D	J	F	M									
													XX	XX	XX	XX	XX	XX																																	
PART V.													S			S			S			S			S			S			S			PROJECT TOTAL																	
Expected Quarterly Expenditures													541,746.30																					\$541,746.30																	

FOR OMB USE ONLY: Resolution No: _____ FMIS Set Up Date: _____ Company No: _____ OMB Analyst: _____



JOHN DEERE

Investment Proposal (Quote)

RDO Equipment Co.
5500 East Penstock Avenue
Flagstaff AZ, 86004
Phone: (928) 526-0639 - Fax: (928) 526-2498

Proposal for:
TEESTO CHAPTER OF THE NAV
PO BOX 7385
WINSLOW, AZ, 860477166
NAVAJO

Investment Proposal Date: 5/8/2023
Pricing Valid Until: 5/22/2023
Deal Number: 1618946
Customer Account#: 8042005
Sales Professional: Buzz Ivcek
Phone: (928) 526-0639
Fax: (928) 526-2498
Email: Blvick@rdoequipment.com

Comments

POSSIBLE 3-5% PRICE INCREASE WITHIN THE NEXT 3-6 MONTHS.

Equipment Information

Quantity	Serial Number Stock Number	Hours (approx.)	Status / Year / Make / Model Additional Items	Cash Price
1	TBD TBD	0	New 2023 JOHN DEERE 724P	\$539,431.00
			Customer Discount SOURCEWELL 35%	(\$179,826.85)
			Warranty -John Deere Comprehensive-36 Months, 3000 Hours,Deductible: 200, Exp Date: 5/7/2026	\$5,454.00
			Item Subtotal:	\$365,058.15
			Equipment Subtotal:	\$365,058.15

Purchase Order Totals

Balance:	\$365,058.15
AZ STATE TAX:	\$21,903.49
AZ COUNTY TAX:	\$0.00
AZ CITY TAX:	\$0.00
Sales Tax Total:	\$21,903.49
Sub Total:	\$386,961.64
Cash with Order:	\$0.00
Balance Due:	\$386,961.64

Equipment Options

Qty	Serial Number	Year / Make / Model	Description
1	TBD	2023 JOHN DEERE 724P	6071DW 724 P Wheel Loader 0202 United States 0259 English 0351 Translated Text Labels 0400 Standard Loader 0451 Standard Z-BAR 0814 Level 1 Trim 0858 Level 3 Performance 8505 Guards - Transmission & Bottom 8502 Maintenance and Service Package 8508 Auxiliary Equipment Package 0951 Rear Camera (Primary Display) 1100 Less Detection System 1602 Steering Wheel 1301 Left Side Steps 183E JDLink™ 2201 Less Payload Scale w/ Cycle Counter 4087 John Deere 9.0L - FT4/SV 6522 Rear Counterweight & Rear Hitch w/ Pin 7026 Joystick Controls 7054 Three Function Hydraulics 5125 Bridgestone VJT - 23.5R25 L3 1-Star Radial Tires w/ 3 PC Rims 5553 Full Coverage Front Fenders 7402 Hydraulic Coupler - JRB 418 Pattern 7807 4.75 YD (3.63 CM) Enhanced Performance 7458 Bolt-On Cutting Edge 7502 76 Inch (1930mm) Wide Fork Frame 7703 72 Inch (1829mm) Construction Tires

House Weatherization



NAVAJO NATION DEPARTMENT OF JUSTICE
OFFICE OF THE ATTORNEY GENERAL

ETHEL B. BRANCH
Attorney General

HEATHER CLAH
Deputy Attorney General

DEPARTMENT OF JUSTICE
INITIAL ELIGIBILITY DETERMINATION
FOR NAVAJO NATION FISCAL RECOVERY FUNDS

RFS/HK Review #: HK 0532

Date & Time Received: 6/6/23 at 10:03

Date & Time of Response: 6/9/23 at 17:00

Entity Requesting FRF: Teesto Chapter

Title of Project: Housing Repair and Weatherization Project

Administrative Oversight: Division of Community Development

Amount of Funding Requested: \$1,132,410

Eligibility Determination:

- FRF eligible
FRF ineligible
Additional information requested

FRF Eligibility Category:

- (1) Public Health and Economic Impact
(2) Premium Pay
(3) Government Services/Lost Revenue
(4) Water, Sewer, Broadband Infrastructure

U.S. Department of Treasury Reporting Expenditure Category:
2.18, Housing Support: Other Housing Assistance

Returned for the following reasons (Ineligibility Reasons/Paragraphs 5.E.(1)-(10) of FRF Procedures):

- | | |
|--|--|
| <input type="checkbox"/> Missing Form | <input type="checkbox"/> Expenditure Plan incomplete |
| <input type="checkbox"/> Supporting documentation missing | <input type="checkbox"/> Funds will not be obligated by 12/31/2024 |
| <input type="checkbox"/> Project will not be completed by 12/31/2026 | <input type="checkbox"/> Incorrect Signatory |
| <input type="checkbox"/> Ineligible purpose | <input type="checkbox"/> Inconsistent with applicable NN or federal laws |
| <input type="checkbox"/> Submitter failed to timely submit CARES reports | |
| <input type="checkbox"/> Additional information submitted is insufficient to make a proper determination | |

Other Comments: _____

Name of DOJ Reviewer: Veronica Blackhat, Asst Attorney General, Natural Resources Unit

Signature of DOJ Reviewer: 

Disclaimers:
If additional information has been requested and you wish to provide it, please resubmit all the required forms updated to include the additional information. Full resubmission will expedite the Initial Eligibility Determination process. Therefore, please include a new RFS form indicating resubmission, revised Appendix A, Budget Form 1, and other supporting documents. **Please email your resubmission to arpa@nndoj.org.** Please be aware that under Resolution BFS-31-21 a Project or Program can only be reviewed twice, therefore it is critical that you include all the requested additional information for your second submission.

An NNDOJ Initial Eligibility Determination is based on the documents provided, which NNDOJ will assume are true, correct, and complete. Should the Project or Program change in any material way after the initial determination, the requestor must seek the advice of NNDOJ. An initial determination is limited to review of the Project or Program as it relates to whether the Project or Program is a legally allowable use – it does not serve as an opinion as to whether or not the Project or Program should be funded, nor does it serve as an opinion as to whether or not the amount requested is reasonable or accurate.

THE NAVAJO NATION
FISCAL RECOVERY FUNDS REQUEST FORM & EXPENDITURE PLAN
FOR GOVERNANCE-CERTIFIED CHAPTERS

Part 1. Identification of parties.

Governance-Certified Chapter requesting FRF: TEESTO CHAPTER Date prepared: 05/22/23

Chapter's Teesto Chapter phone & email: (928)657-8042
mailing address: PO Box 7385 website (if any): teesto@navajochapters.org

This Form prepared by: Clara Tsosie, Manager phone/email: (928)657-8042
c_tsosie@nnchapters.org
CONTACT PERSON'S name and title CONTACT PERSON'S info

Title and type of Project: Housing Repair and Weatherization Project.

Chapter President: Elmer Clark phone & email: 928-606-4136 & clark_elmer@yahoo.com

Chapter Vice-President: Leroy Thomas phone & email: 928-589-7154

Chapter Secretary: Sophia Francis phone & email: 928-313-0529 & sophiafrancis@navajochapters.org

Chapter Treasurer: Sophia Francis phone & email: 928-313-0529 & sophiafrancis@navajochapters.org

Chapter Manager or CSC: Clara Tsosie phone & email: 928-657-8045 & c_tsosie@nnchapters.org

DCD/Chapter ASO: Toni Mina, ASO phone & email: 928-654-3934 & tmina@nndcd.org

List types of Subcontractors or Subrecipients that will be paid with FRF (if known): Carpenter Supervisor and five carpenters.

Will be included on the budget forms. document attached

Amount of FRF requested: \$1,132,410.03 FRF funding period: 05/23/2023 - 12/31/2026
indicate Project starting and ending/deadline date

Part 2. Expenditure Plan details.

(a) Describe the Program(s) and/or Project(s) to be funded, including how the funds will be used, for what purposes, the location(s) to be served, and what COVID-related needs will be addressed:

The housing repair and weatherization project will assist Teesto residents with housing materials to improve and provide adequate living for local residents. This project will restore, renovation & weatherized damaged home in poor condition. Each household will provide cost estimate, scope of work prior to purchasing housing materials. Home improvement will include roofing repair, interior & exterior walls, replacement of windows, interior & exterior doors, interior & exterior walls, flooring, housewiring, plumbing, heating stove, and ADA ramps for entrance, if needed. document attached

(b) Explain how the Program or Project will benefit the Navajo Nation, Navajo communities, or the Navajo People:

Teesto Chapter community members will benefit with the housing repair & weatherization, improve their quality of life, have a safe sanitary homes to ensure physical, emotional and mentally healthy to recover the family livelihood. The home will be improved for adequate and stable living. document attached

(c) A prospective timeline showing the estimated date of completion of the Project and/or each phase of the Project. Disclose any challenges that may prevent you from incurring costs for all funding by December 31, 2024 and/or fully expending funds and completing the Program(s) or Project(s) by December 31, 2026:

The project will begin as soon as monies are available and end on December 31, 2026. This project will provide carpenter supervisor and five carpenters to meet completion of the project. Budget for the project will be provided on the Navajo Nation Budget Forms.

document attached

(d) Identify who will be responsible for implementing the Program or Project:

Clara Tsosie, Chapter Manager
Helen Yazzie, Administrative Assistant
Allen Benally, Maintenance Technician

document attached

(e) Explain who will be responsible for operations and maintenance costs for the Project once completed, and how such costs will be funded prospectively:

The family will provide operation and maintenance after the project is completed.

document attached

(f) State which of the 66 Fiscal Recovery Fund expenditure categories in the attached U.S. Department of the Treasury Appendix 1 listing the proposed Program or Project falls under, and explain the reason why:

6.1 Housing Support: Other Housing Assistance
Eighty percent of homes in Teesto service area are damages, weatherized, unsafe, and dilapidated conditions. This funding assistance will include rehabilitation of homes to Teesto community for healthier environment and sanitary condition homes.

document attached

Part 3. Additional documents.

List here all additional supporting documents attached to this FRF Expenditure Plan (or indicate N/A):

- 1. Budget Forms
- 2. Cost estimate
- 3. Chapter Resolution

Chapter Resolution attached

Part 4. Affirmation by Funding Recipient.

Funding Recipient affirms that its receipt of Fiscal Recovery Funds and the implementation of this FRF Expenditure Plan shall be in accordance with Resolution No. CJY-41-21, the ARPA, ARPA Regulations, and with all applicable federal and Navajo Nation laws, regulations, and policies:

Chapter's Preparer:

signature of Preparer/CONTACT PERSON

Approved by:

signature of Chapter President (or Vice-President)

Approved by:

signature of Chapter Manager or CSC

Approved by:

Toni Mera, ASD
signature of DCD/Chapter ASD

Approved to submit for Review:

signature of DCD Director

FY 2023



THE NAVAJO NATION
PROGRAM BUDGET SUMMARY

Page 01 of 06
BUDGET FORM 1

PART I. Business Unit No.: NEW Program Title: TEESTO CHAPTER *Housing Repair + Weatherization* Division/Branch: NNDCD
 Prepared By: Clara Tsosie Phone No.: 928-657-8042 Email Address: teesto@navajochapters.org

PART II. FUNDING SOURCE(S)	Fiscal Year /Term	Amount	% of Total	PART III. BUDGET SUMMARY	Fund Type Code	(A) NNC Approved Original Budget	(B) Proposed Budget	(C) Difference or Total
Navajo Nation ARPA Funds <i>FRF</i>	5/22/23-12/31/202	\$ 1,132,410.03	100%	2001 Personnel Expenses	6		\$ 256,529.94	
				3000 Travel Expenses				
				3500 Meeting Expenses				
				4000 Supplies				
				5000 Lease and Rental				
				5500 Communications and Utilities				
				6000 Repairs and Maintenance				
				6500 Contractual Services				
				7000 Special Transactions				
				8000 Public Assistance	6		\$ 875,880.09	
				9000 Capital Outlay				
				9500 Matching Funds				
				9500 Indirect Cost				
				TOTAL		\$0.00	\$ 1,132,410.03	0
				PART IV. POSITIONS AND VEHICLES		(D)	(E)	
				Total # of Positions Budgeted:				
				Total # of Vehicles Budgeted:				
		TOTAL:	\$1,132,410.03	100%				

PART V. I HEREBY ACKNOWLEDGE THAT THE INFORMATION CONTAINED IN THIS BUDGET PACKAGE IS COMPLETE AND ACCURATE.

SUBMITTED BY: James Adakai, Acting Program Manager APPROVED BY: Calvin Castillo, Executive Director
 Program Manager's Printed Name Division Director / Branch Chief's Printed Name
 6-5-23  6-5-23
 Program Manager's Signature and Date Division Director / Branch Chief's Signature and Date

THE NAVAJO NATION
PROGRAM PERFORMANCE CRITERIA

PART I. PROGRAM INFORMATION:
 Business Unit No.: NEW Program Name/Title: TEESTO CHAPTER *Housing Repair + Weatherization*

PART II. PLAN OF OPERATION/RESOLUTION NUMBER/PURPOSE OF PROGRAM:
TEE-MAR-14-2023

PART III. PROGRAM PERFORMANCE CRITERIA:	1st QTR		2nd QTR		3rd QTR		4th QTR	
	Goal	Actual	Goal	Actual	Goal	Actual	Goal	Actual
1. Goal Statement: <u>To conduct community housing needs assessment to develop priority list for 16 housing repairs</u> Program Performance Measure/Objective: <u>Review, evaluate, screen and select candidtates for housing repairs</u>	30		30		30		30	
2. Goal Statement: <u>To develop a housing repair strategy.</u> Program Performance Measure/Objective: <u>Determine scope of work for each housing repair project and cost estimate.</u>	30		30		30		30	
3. Goal Statement: <u>To evaluate and select best possible vendor to procure materials</u> Program Performance Measure/Objective: <u>Contact 3 or more vendors for bulk purchase, transport, deliver and other cost.</u>	30		30		30		30	
4. Goal Statement: Program Performance Measure/Objective: 								
5. Goal Statement: Program Performance Measure/Objective: 								

PART IV. I HEREBY ACKNOWLEDGE THAT THE ABOVE INFORMATION HAS BEEN THOROUGHLY REVIEWED.

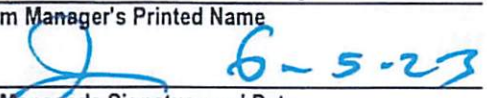
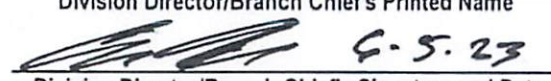
<u>James Adakai, Acting Program Manager</u> Program Manager's Printed Name  Program Manager's Signature and Date	<u>Calvin Castillo, Executive Director</u> Division Director/Branch Chief's Printed Name  Division Director/Branch Chief's Signature and Date
--	---

THE NAVAJO NATION
 DETAILED BUDGET AND JUSTIFICATION

PART I. PROGRAM INFORMATION:			
Program Name/Title: _____		TEESTO CHAPTER <i>Housing Repair and Weatherization</i>	Business Unit No.: _____ NEW
PART II. DETAILED BUDGET:			
(A)	(B)	(C)	(D)
Object Code (LOD 6)	Object Code Description and Justification (LOD 7)	Total by DETAILED Object Code (LOD 6)	Total by MAJOR Object Code (LOD 4)
6			
8000	PUBLIC ASSISTANCE		\$ 875,880.09
8500	INFRASTRUCTURE (NON-CAP)	\$ 875,880.09	
8510	Housing Construction Materials Home repair and weatherization will include roofing repair, interior & exterior walls, replacement of windows, exterior & interior doors, interior & exterior walls, flooring, housewiring, plumbing, heating stove, and ADA ramps for entrance, if needed.		
2001	PERSONNEL EXPENSES		\$ 48,535.80
6	CARPENTRY SUPERVISOR GRADE 62 STEP F	\$ 48,535.80	
2310	2320 \$21.13/HOUR X 2088 HOURS X 01 PERSONNEL		
2900	2910 FICA: 6.20% = \$2,735.41		
	2914 MEDI: 1.45% = \$639.73		
	2951 SUTA: 1.83% = \$807.39		
	2960 WORKER COMP: = \$233.83		
6	CARPENTRY WORKERS GRADE: 60 STEP L		\$ 207,994.14
2310	2320 \$18.11/HOUR X 2088 HOURS X 05 PERSONNEL	\$ 207,994.14	
2900	2910 FICA: 6.20% = \$11,722.24		
	2914 MEDI: 1.45% = \$2,741.49		
	2951 SUTA: 1.83% = \$3,459.95		
	2960 WORKER COMP: = \$1,002.06		
TOTAL		\$ 1,132,410.03	\$ 1,132,410.03

Appendix E
Council
Resolution



The Navajo Nation **DR. BUU NYGREN** **PRESIDENT**
Yideeskáądi Nitsáhákees **RICHELLE MONTOYA** **VICE PRESIDENT**

August 4, 2023

Honorable Crystalyne Curley, Speaker
Navajo Nation Council
Post Office Box 3390
Window Rock, AZ 86515

RE: *CJY-56-23 An Action Relating to the Naabik'iyáti' Committee and Navajo Nation Council; Amending CD-69-22 and the Navajo Nation Fiscal Recovery Fund Delegate Region Project Plan for Honorable Cherilyn Yazzie's Delegate Region (Chapters: Dilkon, Indian Wells, Teesto, Whitecone, Greasewood Springs)*

Dear Speaker Curley,

I am pleased to sign into law this resolution CJY-56-23 approving the Fiscal Recovery Funds Delegate Regional Project Plan for Honorable Yazzie's Delegate Region in the amount of \$3,160,468.

My Administration supports the plans of these Chapters who have worked very hard to put together their Regional Plans and is working very closely with the Fiscal Recovery Fund Office to ensure that these funds are put to use. As such, when Chapters are running into roadblocks in expending their Fiscal Recovery Funds and the roadblock is coming from the Executive Branch, I encourage them to reach out to the Office of the President and Vice President and inform my office of the roadblock and we will work to overcome those roadblocks.

I do want to take the moment to express my concern that any amendments to the Regional Plans must be approved by the Council. In addition, the prior Navajo Nation Council has set the expectation that Fiscal Recovery Funds be encumbered by June 30, 2024. This deadline is not far off. As a construction expert, I know that there are unpredictable factors that can prevent even the best of plans from moving forward on the proposed timeline. We should be designing systems that are flexible, accountable, and transparent. We do not currently have that system and I look forward to working with you and the entire Council to improve the Navajo Nation systems, so we are supporting our communities to take advantage of this historic funding.

Now let's get to work!

Sincerely,

Dr. Buu Nygren, *President*
THE NAVAJO NATION

**RESOLUTION OF THE
NAVAJO NATION COUNCIL
25th NAVAJO NATION COUNCIL - FIRST YEAR, 2023**

AN ACTION

**RELATING TO THE NAABIK'ÍYÁTI' COMMITTEE AND NAVAJO NATION COUNCIL;
AMENDING CD-69-22 AND THE NAVAJO NATION FISCAL RECOVERY FUND
DELEGATE REGION PROJECT PLAN FOR HONORABLE CHERILYN YAZZIE'S
DELEGATE REGION (CHAPTERS: DILKON, INDIAN WELLS, TEESTO,
WHITECONE, GREASEWOOD SPRINGS)**

BE IT ENACTED:

SECTION ONE. AUTHORITY

- A. The Navajo Nation Council is the governing body of the Navajo Nation. 2 N.N.C. § 102(A).
- B. The Naabik'iyáti' Committee is a standing committee of the Navajo Nation Council with the delegated responsibility to hear proposed resolution(s) that require final action by the Navajo Nation Council. 2 N.N.C. § 164(A)(9).
- C. Navajo Nation Council Resolution No. CJN-29-22, incorporated herein by reference, mandates that Navajo Nation Fiscal Recovery Fund ("NNFRF") Delegate Region Project Plans be approved by Navajo Nation Council resolution and signed into law by the President of the Navajo Nation pursuant to 2 N.N.C. § 164(A) and 2 N.N.C. §§ 1005(C)(10), (11), and (12).
- D. Navajo Nation Council Resolution No. CD-69-22, attached as Exhibit 1 (without project exhibits), mandates that amendments to the Navajo Nation Fiscal Recovery Fund Delegate Region Project Plan for Hon. Cherilyn Yazzie's Delegate Region (Chapters: Dilkon, Indian Wells, Teesto, Whitecone, Greasewood Springs) be approved by a Navajo Nation Council resolution and signed into law by the President of the Navajo Nation pursuant to 2 N.N.C. § 164(A)(17), and 2 N.N.C. §§ 1005(C)(10), (11), and (12).

SECTION TWO. FINDINGS

- A. The Navajo Nation Council Resolution No. CJN-29-22, AN ACTION RELATING TO THE NAABIK'ÍYÁTI' COMMITTEE AND NAVAJO NATION COUNCIL; ALLOCATING \$1,070,298,867 OF NAVAJO NATION FISCAL RECOVERY FUNDS; APPROVING THE NAVAJO NATION FISCAL RECOVERY FUND EXPENDITURE PLANS FOR: CHAPTER AND REGIONAL PROJECTS; PUBLIC SAFETY EMERGENCY COMMUNICATIONS, E911, AND RURAL ADDRESSING PROJECTS; CYBER SECURITY; PUBLIC HEALTH PROJECTS;

HARDSHIP ASSISTANCE; WATER AND WASTEWATER PROJECTS; BROADBAND PROJECTS; HOME ELECTRICITY CONNECTION AND ELECTRIC CAPACITY PROJECTS; HOUSING PROJECTS AND MANUFACTURED HOUSING FACILITIES; BATHROOM ADDITION PROJECTS; CONSTRUCTION CONTINGENCY FUNDING; AND REDUCED ADMINISTRATIVE FUNDING, was signed into law by the President of the Navajo Nation on July 15, 2022.

B. CJN-29-22, Section Three, states, in part and among other things, that

1. The Navajo Nation hereby approves total funding for the NNFRF Chapter and Chapter Projects Expenditure Plan from the Navajo Nation Fiscal Recovery Fund in the total amount of two hundred eleven million two hundred fifty-six thousand one hundred forty-eight dollars (\$211,256,148) to be divided equally between the twenty-four (24) Delegate Regions in the amount of eight million eight hundred two thousand three hundred forty dollars (\$8,802,340) per Delegate Region . . . and allocated through Delegate Region Project Plans approved by Navajo Nation Council resolution and signed into law by the President of the Navajo Nation See CJN-29-22, Section Three (B).
2. The Delegate Region Project Plan funding will be allocated to the Navajo Nation Central Government, specifically the Division of Community Development or other appropriate Navajo Nation Division or Department, to implement the projects rather than directly to the Chapters. See CJN-29-22, Section Three (D).
3. The Navajo Nation Central Government, specifically the Division of Community Development or other appropriate Navajo Nation Division or Department, shall manage and administer funds and Delegate Region Project Plans on behalf of Non-LGA-Certified Chapters. The Navajo Nation Central Government may award funding to LGA-Certified Chapters through sub-recipient agreements to implement and manage specific projects, but shall maintain Administrative Oversight over such funding and Delegate Region Project Plans. See CJN-29-22, Section Three (E).
4. Each Navajo Nation Council delegate shall select Fiscal Recovery Fund eligible projects within their Delegate Region to be funded by the NNFRF Chapter and Regional Projects Expenditure Plan through a Delegate Region Projects Plan. The total cost of projects selected by each Delegate shall not exceed their Delegate Region distribution of eight million eight hundred two thousand

three hundred forty dollars (\$8,802,340). See CJN-29-22, Section Three (F).

5. Each Delegate Region Project shall identify its Administrative Oversight entity and its Oversight Committee(s) and be subject CJY-41-21's NNDOJ initial eligibility determination. See CJN-29-22, Section Three (L) (5) and (L) (6).
- C. The Navajo Nation Council Resolution No. CD-69-22, AN ACTION RELATING TO THE NAABIK'ÍYÁTI' COMMITTEE AND NAVAJO NATION COUNCIL; APPROVING THE NAVAJO NATION FISCAL RECOVERY FUND DELEGATE REGION PROJECT PLAN FOR HONORABLE ELMER P. BEGAY'S DELEGATE REGION (CHAPTERS: DILKON, INDIAN WELLS, TEESTO, WHITECONE, GREASEWOOD SPRINGS), was signed into law by the President of the Navajo Nation on January 6, 2023. Exhibit 1.
- D. CD-69-22, Section Four, states that:
1. Amendments to this legislation or to the Delegate Region Project Plan approved herein shall only be adopted by resolution of the Navajo Nation Council and approval of the President of the Navajo Nation pursuant to 2 N.N.C. § 164(A) (17) and 2 N.N.C. §§ 1005(C) (10), (11), and (12).
- E. The Hon. Cherilyn Yazzie has requested to amend CD-69-22 to remove the *Teesto Chapter Feasibility Studies for All Washes in Teesto Service Area* project (under NNDOJ Review No. HK0245) and to remove the *Teesto Chapter ADA Bathroom Additions for 10-Families* project (under NNDOJ Review No. HK0299) from the Delegate Region Projects Plan that covers the Dilkon, Indian Wells, Teesto, Whitecone, Greasewood Springs Chapters. The removal of these projects will revert \$373,291.00 back to Hon. Cherilyn Yazzie's Delegate Region Project Plan's Un-Allocated Amount.
- F. Further, the Hon. Cherilyn Yazzie has requested to amend CD-69-22 to replace the *Teesto Chapter Heavy Equipment Purchase John Deere 724P* project (under NNDOJ Review No. HK0244) with a new NNDOJ Eligibility Determination for the project now under *Teesto Chapter New John Deere 724P* (NNDOJ Review No. HK0534) project and to replace the *Teesto Chapter 2021 John Deere 324G with 2021 JRB48Forks* project (NNDOJ Review No. HK0247) with a new NNDOJ Eligibility Determination for the project now under *Teesto Chapter John Deere 324G with JRB 48FORKS* project (under NNDOJ Review No. HK0533) within the Delegate Region Projects Plan covering the Dilkon, Indian Wells, Teesto, Whitecone, Greasewood Springs Chapters. The replacement of these projects will add \$256,783.99 to Hon. Cherilyn Yazzie's Delegate Region's Project Plan's Allocated Amount.

- G. Further, the Hon. Cherilyn Yazzie has requested that additional projects be added to the Delegate Region Projects Plan covering the Dilkon, Indian Wells, Teesto, Whitecone, Greasewood Springs Chapters originally approved by CD-69-22. The additional projects, which have all been deemed Fiscal Recovery Fund eligible by NNDOJ, as well as the removed and replaced projects, are set forth in Exhibit 2. After the deletion, replacement and addition of the project(s), the Hon. Cherilyn Yazzie's Delegate Region Projects Plan does not exceed the amount of \$8,802,340, as set forth in CJN-29-22, Section Three (F).
- H. The Navajo Nation Council hereby finds that it is in the best interest of the Navajo Nation and the Hon. Cherilyn Yazzie's Delegate Region Chapters and communities to approve and adopt the removal of two-projects, the replacement of two-projects and the addition of additional projects as part of the Navajo Nation Fiscal Recovery Fund Delegate Region Project Plan for Hon. Cherilyn Yazzie's Delegate Region (Chapters: Dilkon, Indian Wells, Teesto, Whitecone, Greasewood Springs) as set forth in Exhibit 2.

SECTION THREE. AMENDING CD-69-22, THE NAVAJO NATION FISCAL RECOVERY FUND DELEGATE REGION PROJECT PLAN FOR HONORABLE CHERILYN YAZZIE'S DELEGATE REGION (CHAPTERS: DILKON, INDIAN WELLS, TEESTO, WHITECONE, GREASEWOOD SPRINGS)

- A. The Navajo Nation hereby approves the removal of two-projects (the *Teesto Chapter Feasibility Studies for All Washes in Teesto Service Area* project under NNDOJ Review No. HK0245 and the *Teesto Chapter ADA Bathroom Additions for 10-Families* project under NNDOJ Review No. HK0299) listed in CD-69-22 for Hon. Cherilyn Yazzie's Delegate Region Projects Plan as stricken in Exhibit 2. The removal of these projects from Hon. Cherilyn Yazzie's Delegate Projects Plan will revert \$373,291.00 back to her Delegate Region's Project Plan's Un-Allocated Amount.
- B. The Navajo Nation hereby approves the replacement of two-projects (the *Teesto Chapter Heavy Equipment Purchase John Deere 724P* project under NNDOJ Review No. HK0244 and the *Teesto Chapter 2021 John Deere 324G with 2021 JRB48Forks* project under NNDOJ Review No. HK0247) listed in CD-69-22 for Hon. Cherilyn Yazzie's Delegate Region Projects Plan as stricken and replaced in Exhibit 2 with new NNDOJ Eligibility Determinations for the two-projects under *Teesto Chapter New John Deere 724P* (under NNDOJ Review No. HK0534) project and the *Teesto Chapter John Deere 324G with JRB 48FORKS* project (under NNDOJ Review No. HK0533). The replacement of these two-projects from Hon.

Cherilyn Yazzie's Delegate Projects Plan will add \$256,783.99 to her Delegate Region's Project Plan's Allocated Amount.

- C. The Navajo Nation hereby approves the additional projects as part of the Navajo Nation Fiscal Recovery Fund Delegate Region Project Plan for Hon. Cherilyn Yazzie's Delegate Region (Chapters: Dilkon, Indian Wells, Teesto, Whitecone, Greasewood Springs) set forth in Exhibit 2.
- D. The Delegate Region Project Plan approved herein shall comply with all applicable provisions of CJY-41-21, CJN-29-22, and BFS-31-21.
- E. Any inconsistencies between this legislation, the Delegate Region Project Plan, and the individual project appendix, shall be resolved in favor of the project appendix reviewed by Department of Justice during their eligibility determination(s).

SECTION FOUR. AMENDMENTS

Amendments to this legislation or to the Delegate Region Project Plan approved herein shall only be adopted by resolution of the Navajo Nation Council and approval of the President of the Navajo Nation pursuant to 2 N.N.C. § 164(A)(17) and 2 N.N.C. §§ 1005(C)(10), (11), and (12).

SECTION FIVE. EFFECTIVE DATE

This legislation shall be effective upon its approval pursuant to 2 N.N.C. § 221(B), 2 N.N.C. § 164(A)(17), and 2 N.N.C. §§ 1005(C)(10), (11), and (12).

SECTION SIX. SAVING CLAUSE

If any provision of this legislation is determined invalid by the Navajo Nation Supreme Court, or by a Navajo Nation District Court without appeal to the Navajo Nation Supreme Court, those provisions of this legislation not determined invalid shall remain the law of the Navajo Nation.

CERTIFICATION

I, hereby, certify that the foregoing resolution was duly considered by the 25th Navajo Nation Council at a duly called meeting in Window Rock, Navajo Nation (Arizona), at which a quorum was present and that the same was passed by a vote of 21 in Favor, and 00 Opposed, on this 18th day of July 2023.



Honorable Crystalyne Curley, Speaker
25th Navajo Nation Council

7/27/23

DATE

Motion: Honorable George H. Tolth
Second: Honorable Rickie Nez

Speaker Crystalyne Curley not voting

ACTION BY THE NAVAJO NATION PRESIDENT:

1. I, hereby, sign into law the foregoing legislation, pursuant to 2 N.N.C. § 1005 (C)(10), on this 4 day of August, 2023.

Buu Nygren, President
Navajo Nation

2. I, hereby, veto the foregoing legislation, pursuant to 2 N.N.C. § 1005 (C)(11), on this _____ day of _____, 2023 for the reason(s) expressed in the attached letter to the Speaker.

Buu Nygren, President
Navajo Nation

3. I, hereby, exercise line-item veto pursuant to the budget line-item veto authority delegated to the President by vote of the Navajo People in 2009, on this _____ day of _____, 2023.

Buu Nygren, President
Navajo Nation

Exhibit 1

THE NAVAJO NATION

JONATHAN NEZ | PRESIDENT MYRON LIZER | VICE PRESIDENT

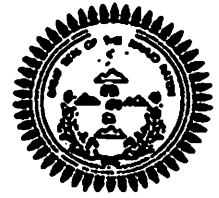

January 6, 2023



Hon. Otto Tso
Office of the Speaker
Post Office Box 3390
Window Rock, AZ 86515

RE: CD-69-22, An Action Relating to the Naabik'iyátl' Committee and Navajo Nation Council; Approving the Navajo Nation Fiscal Recovery Fund Delegate Region Project Plan for Honorable Elmer P. Begay's Delegate Region (Chapters: Dilkon, Indian Wells, Teesto, Whitecone, Greasewood Springs)

Dear Speaker Tso,

The Nez/Lizer Administration appreciates the Chapters' endeavors to work collaboratively with their respective Council Delegate in completing the process to access funding made available with the \$211,256,148 allocated for regional expenditure plans under CJN-29-22.

The process to secure funding also involves collaborative efforts between the Chapters, the Division of Community Development, Navajo Nation Fiscal Recovery Fund (NNFRF) Office and the Navajo Nation Department of Justice (NNDOJ). Per BFS-31-21, each proposed expenditure must obtain NNDOJ verification that each proposed project is an eligible expense within ARPA/NNFRF regulations. Each of the projects within CD-69-22 has met all the requirements.

The ARPA/NNFRF process is still evolving since the inception of this funding. Within the United States Treasury and the Navajo Nation, processes have been updated at various times. An example is the Treasury guidelines referenced within Navajo Nation Council resolutions CJY-41-21 and CJN-29-22; the Treasury guidelines exhibit was updated by the United States Treasury on September 20, 2022. Accordingly, the legal guidance provided by NNDOJ and Office of Legislative Counsel is modified to comply with the Treasury guidelines.

One such modification of legal guidance involved the processing of regional expenditure plans. Originally, the guidance was that all projects had to equal \$8,802,340 to be considered as completed and ready for legislative action. This guidance was modified in December 2022 to allow partial funding of the \$8,802,340 allocations so that proposed ARPA/NNFRF projects ready for legislative action could be processed by Office of Legislative Counsel. Because of the time constraints for the 24th Navajo Nation Council to act on proposed legislation, programs did not have sufficient time to provide written verification to Chapters regarding the change in legal guidance.

THE NAVAJO NATION

JONATHAN NEZ | PRESIDENT MYRON LIZER | VICE PRESIDENT



Pursuant to the authority vested in the Navajo Nation President, I am signing Resolution CD-69-22 into law.

Sincerely,

Jonathan Nez, *President*
THE NAVAJO NATION

Myron Lizer, *Vice President*
THE NAVAJO NATION

**RESOLUTION OF THE
NAVAJO NATION COUNCIL
24th NAVAJO NATION COUNCIL - FOURTH YEAR, 2022**

AN ACTION

**RELATING TO THE NAABIK'ÍYÁTI' COMMITTEE AND NAVAJO NATION COUNCIL;
APPROVING THE NAVAJO NATION FISCAL RECOVERY FUND DELEGATE REGION
PROJECT PLAN FOR HONORABLE ELMER P. BEGAY'S DELEGATE REGION
(CHAPTERS: DILKON, INDIAN WELLS, TEESTO, WHITECONE, GREASEWOOD
SPRINGS)**

BE IT ENACTED:

SECTION ONE. AUTHORITY

- A. The Navajo Nation Council is the governing body of the Navajo Nation. 2 N.N.C. § 102(A).**
- B. The Naabik'iyáti' Committee is a standing committee of the Navajo Nation Council with the delegated responsibility to hear proposed resolution(s) that require final action by the Navajo Nation Council. 2 N.N.C. § 164(A) (9).**
- C. Navajo Nation Council Resolution No. CJN-29-22, incorporated herein by reference, mandates that Navajo Nation Fiscal Recovery Fund ("NNFRF") Delegate Region Project Plans be approved by Navajo Nation Council resolution and signed into law by the President of the Navajo Nation pursuant to 2 N.N.C. § 164(A) and 2 N.N.C. §§ 1005(C) (10), (11), and (12).**

SECTION TWO. FINDINGS

- A. Navajo Nation Council Resolution No. CJN-29-22, AN ACTION RELATING TO THE NAABIK'ÍYÁTI' COMMITTEE AND NAVAJO NATION COUNCIL; ALLOCATING \$1,070,298,867 OF NAVAJO NATION FISCAL RECOVERY FUNDS; APPROVING THE NAVAJO NATION FISCAL RECOVERY FUND EXPENDITURE PLANS FOR: CHAPTER AND REGIONAL PROJECTS; PUBLIC SAFETY EMERGENCY COMMUNICATIONS, E911, AND RURAL ADDRESSING PROJECTS; CYBER SECURITY; PUBLIC HEALTH PROJECTS; HARDSHIP ASSISTANCE; WATER AND WASTEWATER PROJECTS; BROADBAND PROJECTS; HOME ELECTRICITY CONNECTION AND ELECTRIC CAPACITY PROJECTS; HOUSING PROJECTS AND MANUFACTURED HOUSING FACILITIES; BATHROOM ADDITION PROJECTS; CONSTRUCTION CONTINGENCY FUNDING; AND REDUCED ADMINISTRATIVE FUNDING, was signed into law by the President of the Navajo Nation on July 15, 2022.**

B. CJN-29-22, Section Three, states, in part and among other things, that:

1. The Navajo Nation hereby approves total funding for the NNFRF Chapter and Chapter Projects Expenditure Plan from the Navajo Nation Fiscal Recovery Fund in the total amount of two hundred eleven million two hundred fifty-six thousand one hundred forty-eight dollars (\$211,256,148) to be divided equally between the twenty-four (24) Delegate Regions in the amount of eight million eight hundred two thousand three hundred forty dollars (\$8,802,340) per Delegate Region . . . and allocated through Delegate Region Project Plans approved by Navajo Nation Council resolution and signed into law by the President of the Navajo Nation See CJN-29-22, Section Three (B).
2. The Delegate Region Project Plan funding will be allocated to the Navajo Nation Central Government, specifically the Division of Community Development or other appropriate Navajo Nation Division or Department, to implement the projects rather than directly to the Chapters. See CJN-29-22, Section Three (D).
3. The Navajo Nation Central Government, specifically the Division of Community Development or other appropriate Navajo Nation Division or Department, shall manage and administer funds and Delegate Region Project Plans on behalf of Non-LGA-Certified Chapters. The Navajo Nation Central Government may award funding to LGA-Certified Chapters through sub-recipient agreements to implement and manage specific projects, but shall maintain Administrative Oversight over such funding and Delegate Region Project Plans. See CJN-29-22, Section Three (E).
4. Each Navajo Nation Council delegate shall select Fiscal Recovery Fund eligible projects within their Delegate Region to be funded by the NNFRF Chapter and Regional Projects Expenditure Plan through a Delegate Region Projects Plan. The total cost of projects selected by each Delegate shall not exceed their Delegate Region distribution of eight million eight hundred two thousand three hundred forty dollars (\$8,802,340). See CJN-29-22, Section Three (F).
5. Each Delegate Region Project shall identify its Administrative Oversight entity and its Oversight Committee(s) and be subject CJY-41-21's NNDOJ initial eligibility determination. See CJN-29-22, Section Three (L) (5) and (L) (6).

- C. All projects listed in the Hon. Elmer P. Begay's Delegate Region Projects Plan, attached as Exhibit A, have been deemed Fiscal Recovery Fund eligible by NNDOJ. In addition, Hon. Elmer P. Begay's Delegate Region Projects Plan does not exceed the amount of \$8,802,340, as set forth in CJN-29-22, Section Three (F).
- D. The Navajo Nation Council hereby finds that it is in the best interest of the Navajo Nation and the Hon. Elmer P. Begay's Delegate Region Chapters and communities to approve and adopt the Navajo Nation Fiscal Recovery Fund Delegate Region Project Plan for Hon. Elmer P. Begay's Delegate Region (Chapters: Dilkon, Indian Wells, Teesto, Whitecone, Greasewood Springs) as set forth in Exhibit A.

SECTION THREE. APPROVAL OF HON. ELMER P. BEGAY'S DELEGATE REGION PROJECT PLAN

- A. The Navajo Nation hereby approves the Fiscal Recovery Fund Delegate Region Project Plan for Hon. Elmer P. Begay's Delegate Region (Chapters: Dilkon, Indian Wells, Teesto, Whitecone, Greasewood Springs) set forth in Exhibit A.
- B. The Delegate Region Project Plan approved herein shall comply with all applicable provisions of CJY-41-21, CJN-29-22, and BFS-31-21.
- C. Any inconsistencies between this legislation, the Delegate Region Project Plan, and the individual project appendix, shall be resolved in favor of the project appendix reviewed by Department of Justice during their eligibility determination(s).

SECTION FOUR. AMENDMENTS

Amendments to this legislation or to the Delegate Region Project Plan approved herein shall only be adopted by resolution of the Navajo Nation Council and approval of the President of the Navajo Nation pursuant to 2 N.N.C. § 164(A)(17) and 2 N.N.C. §§ 1005(C)(10), (11), and (12).

SECTION FIVE. EFFECTIVE DATE

This legislation shall be effective upon its approval pursuant to 2 N.N.C. § 221(B), 2 N.N.C. § 164(A)(17), and 2 N.N.C. §§ 1005(C)(10), (11), and (12).

SECTION FIVE. SAVING CLAUSE

If any provision of this legislation is determined invalid by the Navajo Nation Supreme Court, or by a Navajo Nation District Court without appeal to the Navajo Nation Supreme Court, those provisions of this legislation not determined invalid shall remain the law of the Navajo Nation.

CERTIFICATION

I hereby certify that the foregoing resolution was duly considered by the 24th Navajo Nation Council at a duly called meeting in Window Rock, Navajo Nation (Arizona), at which a quorum was present and that the same was passed by a vote of 21 in Favor, and 00 Opposed, on this 29th day of December 2022.



Honorable Otto Tso, Speaker
24th Navajo Nation Council

12.30.2022

DATE

Motion: Honorable Jamie Henio
Second: Honorable Eugene Tso

Speaker Otto Tso not voting

ACTION BY THE NAVAJO NATION PRESIDENT:

1. I, hereby, sign into law the foregoing legislation, pursuant to 2 N.N.C. § 1005 (C)(10), on this 10th day of January, 2022.

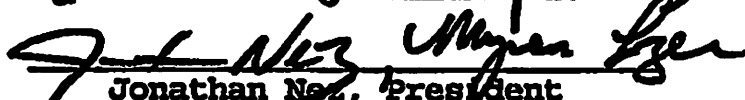
Jonathan Nez, President
Navajo Nation

2. I, hereby, veto the foregoing legislation, pursuant to 2 N.N.C. § 1005 (C)(11), on this _____ day of _____, 2022 for the reason(s) expressed in the attached letter to the Speaker.

Jonathan Nez, President
Navajo Nation

3. I, hereby, exercise line-item veto pursuant to the budget line-item veto authority delegated to the President by vote of the Navajo People in 2009, on this _____ day of _____, 2022.

Jonathan Nez, President
Navajo Nation

NAVAJO NATION FISCAL RECOVERY FUND DELEGATE REGION PROJECT PLAN



COUNCIL DELEGATE: Delegate Elmer P. Begay

CHAPTERS: Dilcon, Indian Wells, Teesto, Whitecone, Greasewood Springs

FUNDING RECIPIENT	SUBRECIPIENT	EXPENDITURE PLAN / PROJECT	ADMIN OVERSIGHT	FRF CATEGORY	DOJ REVIEW #	AMOUNT
Division of Community Development	NONE IDENTIFIED	White Cone Chapter Community Cemetery Clearance Needs	Division of Community Development	6.1	HK0227	\$ 1,000.00
Division of Community Development	*Greasewood Springs Chapter	Greasewood Springs Chapter Reservoir/Aquifer Recharge Project	Division of Community Development	2.22	HK0240	\$ 200,000.00
Division of Community Development	*Teesto Chapter	Teesto Chapter Heavy Equipment Purchase (John Deere 724P)	Division of Community Development	6.1	HK0244	\$ 317,445.81
Division of Community Development	*Teesto Chapter	Teesto Chapter Feasibility Studies for All Washes in Teesto Service Area	Division of Community Development	2.22	HK0245	\$ 300,000.00
Division of Community Development	*Teesto Chapter	Teesto Chapter 2021 John Deere 324G with 2021 JRB 48FORKS	Elmer Clark, Teesto Chapter President	6.1	HK0247	\$ 53,828.20
Division of Community Development	NONE IDENTIFIED	Indian Wells Chapter Housing Renovations	Division of Community Development	2.18	HK0250	\$ 1,760,468.00
Division of Community Development	*Dilkon Chapter	Dilkon Chapter Home Rehabilitation Project	Division of Community Development	2.18	HK0252	\$ 1,760,467.00
Division of Community Development	NONE IDENTIFIED	White Cone Chapter House Repair & Improvement	Division of Community Development	2.18	HK0296	\$ 1,759,468.00
Division of Community Development	*Teesto Chapter	Teesto Chapter ADA Bathroom Additions for 10-Families	Division of Community Development	1.14	HK0299	\$ 73,291.00
		UN-ALLOCATED AMOUNT				\$ 2,576,371.99

*Per CJN-29-22, Section Three (E), the "Navajo Nation Central Government may award funding to LGA-Certified Chapters through sub-recipient agreements to implement and manage specific projects, but shall maintain Administrative Oversight over such funding and Delegate Region Project Plans."

TOTAL: \$ 8,802,340.00

Exhibit 2

NAVAJO NATION FISCAL RECOVERY FUND DELEGATE REGION PROJECT PLAN



COUNCIL DELEGATE: Hon. Cherilyn Yazzie

CHAPTERS: Dilkon, Indian Wells, Teesto, Whitecone, Greasewood Springs

FUNDING RECIPIENT	SUBRECIPIENT	EXPENDITURE PLAN / PROJECT	ADMIN OVERSIGHT	FRF CATEGORY	DOJ REVIEW #	AMOUNT
		TOTAL AMOUNT APPROPRIATED in CD-69-22 on January 6, 2023				\$ 6,225,968.01
Division of Community Development	*Teesto Chapter	(Remove) Teesto Chapter Feasibility Studies for All Washes in Teesto Service Area	Division of Community Development	2.22	HK0245	-\$ 300,000.00
Division of Community Development	*Teesto Chapter	(Remove) Teesto Chapter ADA Bathroom Additions for 10 Families	Division of Community Development	1.14	HK0299	-\$ 73,291.00
Division of Community Development	*Teesto Chapter	(Replace) Teesto Chapter Heavy Equipment Purchase (John Deere 724P)	Division of Community Development	6.1	HK0244	-\$ 317,445.81
Division of Community Development	*Teesto Chapter	(Replace) Teesto Chapter 2021 John Deere 324G with 2021 JRB 48FORKS	Division of Community Development	6.1	HK0247	-\$ 53,828.20
Division of Community Development	*Teesto Chapter	Teesto Chapter New John Deere 724P	Division of Community Development	6.1	HK0534	\$ 541,746.00 *
Division of Community Development	*Teesto Chapter	Teesto Chapter John Deere 324G with JRB 48FORKS - Forklift	Division of Community Development	6.1	HK0533	\$ 86,312.00 *
Division of Community Development	*Greasewood Springs Chapter	Greasewood Springs Chapter Home Repair/Renovation Project	Division of Community Development	2.18	HK0242-2	\$ 1,400,000.00
Division of Community Development	*Teesto Chapter	Teesto Chapter Housing Repair and Weatherization Project	Division of Community Development	2.18	HK0532	\$ 1,132,410.00 *
		UNALLOCATED AMOUNT				\$ 160,469.00

*Per CJN-29-22, Section Three (E), the "Navajo Nation Central Government may award funding to LGA-Certified Chapters through sub-recipient agreements to implement and manage specific projects, but shall maintain Administrative Oversight over such funding and Delegate Region Project Plans."

TOTAL: \$ 8,802,340.00

Exhibit F

OMB Approved No. 1505-0271
Expiration Date: 11/30/2021

**U.S. DEPARTMENT OF THE TREASURY
CORONAVIRUS STATE AND LOCAL FISCAL RECOVERY FUNDS**

Recipient name and address: The Navajo Nation PO Box 7440 Window Rock, Arizona 86515-7440	DUNS Number: 009001702 Taxpayer Identification Number: 860092335 Assistance Listing Number and Title: 21.027
---	---

Sections 602(b) and 603(b) of the Social Security Act (the Act) as added by section 9901 of the American Rescue Plan Act, Pub. L. No. 117-2 (March 11, 2021) authorizes the Department of the Treasury (Treasury) to make payments to certain recipients from the Coronavirus State Fiscal Recovery Fund and the Coronavirus Local Fiscal Recovery Fund.

Recipients hereby agrees, as a condition to receiving such payment from Treasury, agrees to the terms attached hereto.

Recipient:

Authorized Representative Signature (above)

Authorized Representative Name: Jonathan Nez
Authorized Representative Title: President
Date Signed: _____

U.S. Department of the Treasury:



Authorized Representative Signature (above)

Authorized Representative Name: Jacob Leibenluft
Authorized Representative Title: Chief Recovery Officer, Office of Recovery Programs
Date Signed: May 27, 2021

PAPERWORK REDUCTION ACT NOTICE

The information collected will be used for the U.S. Government to process requests for support. The estimated burden associated with this collection of information is 15 minutes per response. Comments concerning the accuracy of this burden estimate and suggestions for reducing this burden should be directed to the Office of Privacy, Transparency and Records, Department of the Treasury, 1500 Pennsylvania Ave., N.W., Washington, D.C. 20220. DO NOT send the form to this address. An agency may not conduct or sponsor, and a person is not required to respond to, a collection of information unless it displays a valid control number assigned by OMB.

**U.S. DEPARTMENT OF THE TREASURY
CORONAVIRUS STATE FISCAL RECOVERY FUND
AWARD TERMS AND CONDITIONS**

1. Use of Funds.

- a. Recipient understands and agrees that the funds disbursed under this award may only be used in compliance with sections 602(c) and 603(c) of the Social Security Act (the Act) and Treasury's regulations implementing that section and guidance.
- b. Recipient will determine prior to engaging in any project using this assistance that it has the institutional, managerial, and financial capability to ensure proper planning, management, and completion of such project.

2. Period of Performance. The period of performance for this award begins on the date hereof and ends on December 31, 2026. As set forth in Treasury's implementing regulations, Recipient may use award funds to cover eligible costs incurred during the period that begins on March 3, 2021 and ends on December 31, 2024.

3. Reporting. Recipient agrees to comply with any reporting obligations established by Treasury, as it relates to this award.

4. Maintenance of and Access to Records

- a. Recipient shall maintain records and financial documents sufficient to evidence compliance with sections 602(c) and 603(c), Treasury's regulations implementing those sections, and guidance regarding the eligible uses of funds.
- b. The Treasury Office of Inspector General and the Government Accountability Office, or their authorized representatives, shall have the right of access to records (electronic and otherwise) of Recipient in order to conduct audits or other investigations.
- c. Records shall be maintained by Recipient for a period of five (5) years after all funds have been expended or returned to Treasury, whichever is later.

5. Pre-award Costs. Pre-award costs, as defined in 2 C.F.R. § 200.458, may not be paid with funding from this award.

6. Administrative Costs. Recipient may use funds provided under this award to cover both direct and indirect costs.

7. Cost Sharing. Cost sharing or matching funds are not required to be provided by Recipient.

8. Conflicts of Interest. Recipient understands and agrees it must maintain a conflict of interest policy consistent with 2 C.F.R. § 200.318(c) and that such conflict of interest policy is applicable to each activity funded under this award. Recipient and subrecipients must disclose in writing to Treasury or the pass-through entity, as appropriate, any potential conflict of interest affecting the awarded funds in accordance with 2 C.F.R. § 200.112.

9. Compliance with Applicable Law and Regulations.

- a. Recipient agrees to comply with the requirements of sections 602 and 603 of the Act, regulations adopted by Treasury pursuant to sections 602(f) and 603(f) of the Act, and guidance issued by Treasury regarding the foregoing. Recipient also agrees to comply with all other applicable federal statutes, regulations, and executive orders, and Recipient shall provide for such compliance by other parties in any agreements it enters into with other parties relating to this award.
- b. Federal regulations applicable to this award include, without limitation, the following:
 - i. Uniform Administrative Requirements, Cost Principles, and Audit Requirements for Federal Awards, 2 C.F.R. Part 200, other than such provisions as Treasury may determine are inapplicable to this Award and subject to such exceptions as may be otherwise provided by Treasury. Subpart F – Audit Requirements of the Uniform Guidance, implementing the Single Audit Act, shall apply to this award.
 - ii. Universal Identifier and System for Award Management (SAM), 2 C.F.R. Part 25, pursuant to which the award term set forth in Appendix A to 2 C.F.R. Part 25 is hereby incorporated by reference.
 - iii. Reporting Subaward and Executive Compensation Information, 2 C.F.R. Part 170, pursuant to which the award term set forth in Appendix A to 2 C.F.R. Part 170 is hereby incorporated by reference.
 - iv. OMB Guidelines to Agencies on Governmentwide Debarment and Suspension (Nonprocurement), 2 C.F.R. Part 180, including the requirement to include a term or condition in all lower tier covered transactions (contracts and subcontracts described in 2 C.F.R. Part 180, subpart B) that the award is subject to 2 C.F.R. Part 180 and Treasury's implementing regulation at 31 C.F.R. Part 19.

v. Recipient Integrity and Performance Matters, pursuant to which the award term set forth in 2 C.F.R. Part 200, Appendix XII to Part 200 is hereby incorporated by reference.

vi. Governmentwide Requirements for Drug-Free Workplace, 31 C.F.R. Part 20.

vii. New Restrictions on Lobbying, 31 C.F.R. Part 21.

viii. Uniform Relocation Assistance and Real Property Acquisitions Act of 1970 (42 U.S.C. §§ 4601-4655) and implementing regulations.

ix. Generally applicable federal environmental laws and regulations.

c. Statutes and regulations prohibiting discrimination applicable to this award, include, without limitation, the following:

i. Title VI of the Civil Rights Act of 1964 (42 U.S.C. §§ 2000d et seq.) and Treasury's implementing regulations at 31 C.F.R. Part 22, which prohibit discrimination on the basis of race, color, or national origin under programs or activities receiving federal financial assistance;

ii. The Fair Housing Act, Title VIII of the Civil Rights Act of 1968 (42 U.S.C. §§ 3601 et seq.), which prohibits discrimination in housing on the basis of race, color, religion, national origin, sex, familial status, or disability;

iii. Section 504 of the Rehabilitation Act of 1973, as amended (29 U.S.C. § 794), which prohibits discrimination on the basis of disability under any program or activity receiving federal financial assistance;

iv. The Age Discrimination Act of 1975, as amended (42 U.S.C. §§ 6101 et seq.), and Treasury's implementing regulations at 31 C.F.R. Part 23, which prohibit discrimination on the basis of age in programs or activities receiving federal financial assistance; and

v. Title II of the Americans with Disabilities Act of 1990, as amended (42 U.S.C. §§ 12101 et seq.), which prohibits discrimination on the basis of disability under programs, activities, and services provided or made available by state and local governments or instrumentalities or agencies thereto.

10. Remedial Actions. In the event of Recipient's noncompliance with sections 602 and 603 of the Act, other applicable laws, Treasury's implementing regulations, guidance, or any reporting or other program requirements, Treasury may impose additional conditions on the receipt of a subsequent tranche of future award funds, if any, or take other available remedies as set forth in 2 C.F.R. § 200.339. In the case of a violation of sections 602(c) or 603(c) of the Act regarding the use of funds, previous payments shall be subject to recoupment as provided in sections 602(e) and 603(e) of the Act.

11. Hatch Act. Recipient agrees to comply, as applicable, with requirements of the Hatch Act (5 U.S.C. §§ 1501-1508 and 7324-7328), which limit certain political activities of State or local government employees whose principal employment is in connection with an activity financed in whole or in part by this federal assistance.

12. False Statements. Recipient understands that making false statements or claims in connection with this award is a violation of federal law and may result in criminal, civil, or administrative sanctions, including fines, imprisonment, civil damages and penalties, debarment from participating in federal awards or contracts, and/or any other remedy available by law.

13. Publications. Any publications produced with funds from this award must display the following language: "This project [is being] [was] supported, in whole or in part, by federal award number [enter project FAIN] awarded to The Navajo Nation by the U.S. Department of the Treasury."

14. Debts Owed the Federal Government.

a. Any funds paid to Recipient (1) in excess of the amount to which Recipient is finally determined to be authorized to retain under the terms of this award; (2) that are determined by the Treasury Office of Inspector General to have been misused; or (3) that are determined by Treasury to be subject to a repayment obligation pursuant to sections 602(e) and 603(e) of the Act and have not been repaid by Recipient shall constitute a debt to the federal government.

b. Any debts determined to be owed the federal government must be paid promptly by Recipient. A debt is delinquent if it has not been paid by the date specified in Treasury's initial written demand for payment, unless other satisfactory arrangements have been made or if the Recipient knowingly or improperly retains funds that are a debt as defined in paragraph 14(a). Treasury will take any actions available to it to collect such a debt.

15. Disclaimer.

- a. **The United States expressly disclaims any and all responsibility or liability to Recipient or third persons for the actions of Recipient or third persons resulting in death, bodily injury, property damages, or any other losses resulting in any way from the performance of this award or any other losses resulting in any way from the performance of this award or any contract, or subcontract under this award.**
- b. **The acceptance of this award by Recipient does not in any way establish an agency relationship between the United States and Recipient.**

16. Protections for Whistleblowers.

- a. **In accordance with 41 U.S.C. § 4712, Recipient may not discharge, demote, or otherwise discriminate against an employee in reprisal for disclosing to any of the list of persons or entities provided below, information that the employee reasonably believes is evidence of gross mismanagement of a federal contract or grant, a gross waste of federal funds, an abuse of authority relating to a federal contract or grant, a substantial and specific danger to public health or safety, or a violation of law, rule, or regulation related to a federal contract (including the competition for or negotiation of a contract) or grant.**
- b. **The list of persons and entities referenced in the paragraph above includes the following:**
 - i. **A member of Congress or a representative of a committee of Congress;**
 - ii. **An Inspector General;**
 - iii. **The Government Accountability Office;**
 - iv. **A Treasury employee responsible for contract or grant oversight or management;**
 - v. **An authorized official of the Department of Justice or other law enforcement agency;**
 - vi. **A court or grand jury; or**
 - vii. **A management official or other employee of Recipient, contractor, or subcontractor who has the responsibility to investigate, discover, or address misconduct.**
- c. **Recipient shall inform its employees in writing of the rights and remedies provided under this section, in the predominant native language of the workforce.**

17. Increasing Seat Belt Use in the United States. Pursuant to Executive Order 13043, 62 FR 19217 (Apr. 18, 1997), Recipient should encourage its contractors to adopt and enforce on-the-job seat belt policies and programs for their employees when operating company-owned, rented or personally owned vehicles.

18. Reducing Text Messaging While Driving. Pursuant to Executive Order 13513, 74 FR 51225 (Oct. 6, 2009), Recipient should encourage its employees, subrecipients, and contractors to adopt and enforce policies that ban text messaging while driving, and Recipient should establish workplace safety policies to decrease accidents caused by distracted drivers.

ASSURANCE OF COMPLIANCE WITH CIVIL RIGHTS REQUIREMENTS

ASSURANCE OF COMPLIANCE WITH TITLE VI OF THE CIVIL RIGHTS ACT OF 1964

As a condition of receipt of federal financial assistance from the Department of the Treasury, the The Navajo Nation (hereinafter referred to as "the Recipient") provides the assurances stated herein. The federal financial assistance may include federal grants, loans and contracts to provide assistance to the recipient's beneficiaries, the use or rent of Federal land or property at below market value, Federal training, a loan of Federal personnel, subsidies, and other arrangements with the intention of providing assistance. Federal financial assistance does not encompass contracts of guarantee or insurance, regulated programs, licenses, procurement contracts by the Federal government at market value, or programs that provide direct benefits. This assurance applies to all federal financial assistance from or funds made available through the Department of the Treasury, including any assistance that the Recipient may request in the future.

The Civil Rights Restoration Act of 1987 provides that the provisions of this assurance apply to all of the recipient's programs, services and activities, so long as any portion of the recipient's program(s) is federally assisted in the manner proscribed above.

1. Recipient ensures its current and future compliance with Title VI of the Civil Rights Act of 1964, as amended, which prohibits exclusion from participation, denial of the benefits of, or subjection to discrimination under programs and activities receiving federal funds, of any person in the United States on the ground of race, color, or national origin (42 U.S.C. § 2000d et seq.), as implemented by the Department of the Treasury Title VI regulations at 31 CFR Part 22 and other pertinent executive orders such as Executive Order 13166; directives; circulars; policies; memoranda and/or guidance documents.
2. Recipient acknowledges that Executive Order 13166, "Improving Access to Services for Persons with Limited English Proficiency," seeks to improve access to federally assisted programs and activities for individuals who, because of national origin, have Limited English proficiency (LEP). Recipient understands that denying a person access to its programs, services, and activities because of LEP is a form of national origin discrimination prohibited under Title VI of the Civil Rights Act of 1964 and the Department of the Treasury's implementing regulations. Accordingly, Recipient shall initiate reasonable steps, or comply with the Department of the Treasury's directives, to ensure that LEP persons have meaningful access to its programs, services, and activities. Recipient understands and agrees that meaningful access may entail providing language assistance services, including oral interpretation and written translation where necessary, to ensure effective communication in the Recipient's programs, services, and activities.
3. Recipient agrees to consider the need for language services for LEP persons during development of applicable budgets and when conducting programs, services and activities. As a resource, the Department of the Treasury has published its LEP guidance at 70 FR 6067. For more information on LEP, please visit <http://www.lep.gov>.
4. Recipient acknowledges and agrees that compliance with this assurance constitutes a condition of continued receipt of federal financial assistance and is binding upon Recipient and Recipient's successors, transferees and assignees for the period in which such assistance is provided.
5. Recipient acknowledges and agrees that it must require any sub-grantees, contractors, subcontractors, successors, transferees, and assignees to comply with assurances 1-4 above, and agrees to incorporate the following language in every contract or agreement subject to Title VI and its regulations between the Recipient and the Recipient's sub-grantees, contractors, subcontractors, successors, transferees, and assignees:

The sub-grantee, contractor, subcontractor, successor, transferee, and assignee shall comply with Title VI of the Civil Rights Act of 1964, which prohibits recipients of federal financial assistance from excluding from a program or activity, denying benefits of, or otherwise discriminating against a person on the basis of race, color, or national origin (42 U.S.C. § 2000d et seq.), as implemented by the Department of the Treasury's Title VI regulations, 31 CFR Part 22, which are herein incorporated by reference and made a part of this contract (or agreement). Title VI also includes protection to persons with "Limited English Proficiency" in any program or activity receiving federal financial assistance, 42 U.S.C. § 2000d et seq., as implemented by the Department of the Treasury's Title VI regulations, 31 CFR Part 22, and herein incorporated by reference and made a part of this contract or agreement.

6. Recipient understands and agrees that if any real property or structure is provided or improved with the aid of federal financial assistance by the Department of the Treasury, this assurance obligates the Recipient, or in the case of a subsequent transfer, the transferee, for the period during which the real property or structure is used for a purpose for which the federal financial assistance is extended or for another purpose involving the provision of similar services or benefits. If any

personal property is provided, this assurance obligates the Recipient for the period during which it retains ownership or possession of the property;

7. Recipient shall cooperate in any enforcement or compliance review activities by the Department of the Treasury of the aforementioned obligations. Enforcement may include investigation, arbitration, mediation, litigation, and monitoring of any settlement agreements that may result from these actions. That is, the Recipient shall comply with information requests, on-site compliance reviews, and reporting requirements.
8. Recipient shall maintain a complaint log and inform the Department of the Treasury of any complaints of discrimination on the grounds of race, color, or national origin, and limited English proficiency covered by Title VI of the Civil Rights Act of 1964 and implementing regulations and provide, upon request, a list of all such reviews or proceedings based on the complaint, pending or completed, including outcome. Recipient also must inform the Department of the Treasury if Recipient has received no complaints under Title VI.
9. Recipient must provide documentation of an administrative agency's or court's findings of non-compliance of Title VI and efforts to address the non-compliance, including any voluntary compliance or other agreements between the Recipient and the administrative agency that made the finding. If the Recipient settles a case or matter alleging such discrimination, the Recipient must provide documentation of the settlement. If Recipient has not been the subject of any court or administrative agency finding of discrimination, please so state.
10. If the Recipient makes sub-awards to other agencies or other entities, the Recipient is responsible for ensuring that sub-recipients also comply with Title VI and other applicable authorities covered in this document. State agencies that make sub-awards must have in place standard grant assurances and review procedures to demonstrate that they are effectively monitoring the civil rights compliance of sub-recipients.

The United States of America has the right to seek judicial enforcement of the terms of this assurance document and nothing in this document alters or limits the federal enforcement measures that the United States may take in order to address violations of this document or applicable federal law.

Under penalty of perjury, the undersigned official(s) certifies that he/she has read and understood its obligations as herein described, that any information submitted in conjunction with this assurance document is accurate and complete, and that the Recipient is in compliance with the aforementioned nondiscrimination requirements.

Recipient

Date

Signature of Authorized Official:

PAPERWORK REDUCTION ACT NOTICE

The information collected will be used for the U.S. Government to process requests for support. The estimated burden associated with this collection of information is 15 minutes per response. Comments concerning the accuracy of this burden estimate and suggestions for reducing this burden should be directed to the Office of Privacy, Transparency and Records, Department of the Treasury, 1500 Pennsylvania Ave., N.W., Washington, D.C. 20220. DO NOT send the form to this address. An agency may not conduct or sponsor, and a person is not required to respond to, a collection of information unless it displays a valid control number assigned by OMB.

Exhibit G

Compliance and Reporting Guidance

State and Local Fiscal Recovery Funds

